

---

# Clarke®

Division of  
**ALTO®**

OPERATOR'S  
MANUAL &  
PARTS LIST



ENCORE MAX  
SCRUBBER

Beginning with Serial Number 180001

## READ THIS BOOK

This book has important information for the use and safe operation of this machine. Failure to read this book prior to operating or attempting any service or maintenance procedure to your machine could result in injury to you or to other personnel; damage to the machine or to other property could occur as well. you must have training in the operation of this machine before using it. If you or your operator(s) cannot read English, have this manual explained fully before attempting to operate this machine.

All directions given in this book are as seen from the operator's position at the rear of the machine.

For new books, write to: Clarke 2100 Highway 265, Springdale, Arkansas 72764



FILE A2287



**C**

CONTROLS 21

**D**

DECIMAL-METRIC CONVERSION TABLE 5

DISCLAIMER 4

**E**

ELECTRICAL SCHEMATIC 53

**H**

HARDWARE ABBREVIATIONS 6

HYDRAULIC TORQUE REQUIREMENTS 8

**I**

INDEX 3

**M**

MACHINE PREPARATION 17

MAINTENANCE 39

**O**

OPERATING INSTRUCTIONS 30

ORDERING PARTS 10

**S**

SAFETY PRECAUTIONS 11

SPECIFICATIONS 14

STANDARD HARDWARE & TORQUE VALUES 7

SYMBOLS 9

**T**

TROUBLESHOOTING 50

**W**

WIRE HARNESS CONNECTIONS 54

WIRE HARNESS CONNECTIONS-SPRAY WAND 58

WIRE HARNESS ROUTING & CONNECTIONS 56

## **DISCLAIMER**

---

### **DISCLAIMER**

The information contained in this manual is believed correct at the time of publication. American Lincoln assumes no responsibility or liability for unauthorized changes made to this manual or pages removed, causing indirect or consequential damages resulting from the use of the information appearing herein.

### **WARNING!**

In the event that machinery or controls described herein are modified in any way, or in the event that such machinery or controls are not maintained in a proper manner, the instructional material contained herein may be rendered inaccurate. The information contained herein is to be used only by persons knowledgeable in the operation of machinery such as that described herein, or other persons being directly supervised by such knowledgeable persons.

No portion of this manual may be reproduced without the express written consent of:

CLARKE

Product Engineering

1100 Haskins Road

Bowling Green, OH 43402

Telephone: (419) 352-7511 Fax: (419) 373-4284

Copyright 2003 Clarke. All rights reserved.

Printed in USA March 2003

## DECIMAL-METRIC CONVERSIONTABLE

FRACTION	DECIMAL	MILLIMETER	FRACTION	DECIMAL	MILLIMETER
$\frac{1}{64}$	0.015625	0.3969	$\frac{33}{64}$	0.515625	13.0969
$\frac{1}{32}$	0.03125	0.7938	$\frac{17}{32}$	0.53125	13.4938
$\frac{3}{64}$	0.046875	1.1906	$\frac{35}{64}$	0.546875	13.8906
$\frac{1}{16}$	0.0625	1.5875	$\frac{9}{16}$	0.5625	14.2875
$\frac{5}{64}$	0.078125	1.9844	$\frac{37}{64}$	0.578125	14.6844
$\frac{3}{32}$	0.09375	2.3813	$\frac{19}{32}$	0.59375	15.0813
$\frac{7}{64}$	0.109375	2.7781	$\frac{39}{64}$	0.609375	15.4781
$\frac{1}{8}$	0.125	3.1750	$\frac{5}{8}$	0.625	15.8750
$\frac{9}{64}$	0.140625	3.5719	$\frac{41}{64}$	0.640625	16.2719
$\frac{5}{32}$	0.15625	3.9688	$\frac{21}{32}$	0.65625	16.6688
$\frac{11}{64}$	0.171875	4.3656	$\frac{43}{64}$	0.671875	17.0656
$\frac{3}{16}$	0.1875	4.7625	$\frac{11}{16}$	0.6875	17.4625
$\frac{13}{64}$	0.203125	5.1594	$\frac{45}{64}$	0.703125	17.8594
$\frac{7}{32}$	0.21875	5.5563	$\frac{23}{32}$	0.71875	18.2563
$\frac{15}{64}$	0.234375	5.9531	$\frac{47}{64}$	0.734375	18.6531
$\frac{1}{4}$	0.25	6.3500	$\frac{3}{4}$	0.75	19.0500
$\frac{17}{64}$	0.265625	6.7469	$\frac{49}{64}$	0.765625	19.4469
$\frac{9}{32}$	0.28125	7.1438	$\frac{25}{32}$	0.78125	19.8438
$\frac{19}{64}$	0.296875	7.5406	$\frac{51}{64}$	0.796875	20.2406
$\frac{5}{16}$	0.3125	7.9375	$\frac{13}{16}$	0.8125	20.6375
$\frac{21}{64}$	0.328125	8.3344	$\frac{53}{64}$	0.828125	21.0344
$\frac{11}{32}$	0.34375	8.7313	$\frac{27}{32}$	0.84375	21.4313
$\frac{23}{64}$	0.359375	9.1281	$\frac{55}{64}$	0.859375	21.8281
$\frac{3}{8}$	0.375	9.5250	$\frac{7}{8}$	0.875	22.2250
$\frac{25}{64}$	0.390625	9.9219	$\frac{57}{64}$	0.890625	22.6219
$\frac{13}{32}$	0.40625	10.3188	$\frac{29}{32}$	0.90625	23.0188
$\frac{27}{64}$	0.421875	10.7156	$\frac{59}{64}$	0.921875	23.4156
$\frac{7}{16}$	0.4375	11.1125	$\frac{15}{16}$	0.9375	23.8125
$\frac{29}{64}$	0.453125	11.5094	$\frac{61}{64}$	0.953125	24.2094
$\frac{15}{32}$	0.46875	11.9063	$\frac{31}{32}$	0.96875	24.6063
$\frac{31}{64}$	0.484375	12.3031	$\frac{63}{64}$	0.984375	25.0031
$\frac{1}{2}$	0.5	12.7000	$1$	1.0000	25.4000

## HARDWARE ABBREVIATIONS

### ABBREVIATIONS - SCREWS

ADJ	= Adjusting Screw
ADJ.SP	= Adjusting Plunger Screw
BHM	= Binding Head Machine Screw
BHS	= Button Head Socket Screw
CAPT.SL	= Captivated Slotted Screw
CAPT.WG	= Captivated Wing Screw
FHM	= Flat Head Machine Screw
FIL.HM	= Filister Head Machine Screw
HHC	= Hexagon Head Cap Screw
HHM	= Hexagon Head Machine Screw
HIHD	= 1/2 High Head Screw
HSHC	= Hexagonal Socket Head Cap Screw
HSFHC	= Hexagonal Socket Flat Head Cap Screw
KNH	= Knurled Head Screw
MHHC	= Metric Hexagon Head Cap Screw
PHM	= Pan Head Machine Screw
RHD	= Round Head Drive Screw
RHM	= Round Head Machine Screw
RHW	= Round Head Wood Screw
SHC	= Shiny Crown Cap Screw
SHTB	= Shoulder Thumb Screw
SQ	= Square Head Screw
TB	= Thumb Screw
THM	= Truss Head Machine Screw
WELD	= Weld Stud
WG	= Wing Screw

### ABBREVIATIONS - SETSCREWS

HS	= Hexagonal Socket Setscrew
S	= Slotted Setscrew
SH	= Square Head Setscrew
-KCP	= Knurled Cup Point Setscrew
-CP	= Cup Point Setscrew
-OP	= Oval Point Setscrew
-FDP	= Full Dog Point Setscrew
-HDP	= Half Dog Point Setscrew
-FP	= Flat Point Setscrew
-COP	= Cone Point Setscrew

## BOLT IDENTIFICATION

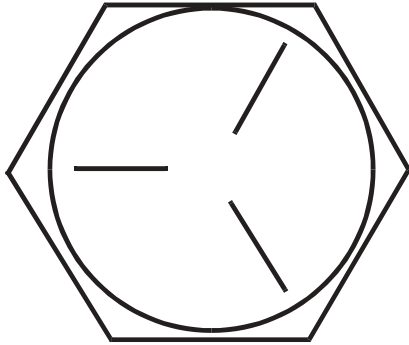

SAE - Grade 5

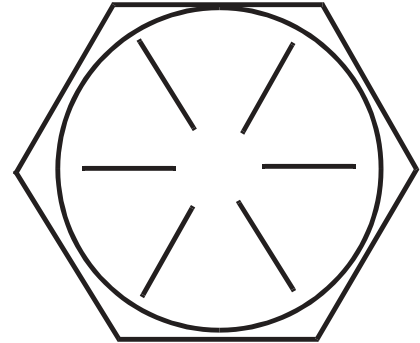

SAE - Grade 8

Screw Size	Grade 5 Plated		Grade 8 Plated		410H Stainless		Brass	Type F & T & BT		Type B, AB
	C	F	C	F	C	F		C	F	
*6	14	15	-	-	18	20	5	20	23	21
*8	27	28	-	-	33	35	9	37	41	34
*10	39	43	-	-	47	54	13	49	64	49
*1/4	86	108	130	151	114	132	32	120	156	120
5/16	15	17	22	24	19	22	6	-	-	-
3/8	28	31	40	44	34	39	10	-	-	-
7/16	44	49	63	70	55	62	16	-	-	-
1/2	68	76	95	108	85	95	-	-	-	-
9/16	98	110	138	155	-	-	-	-	-	-
5/8	135	153	191	216	-	-	-	-	-	-
3/4	239	267	338	378	-	-	-	-	-	-
7/8	387	-	545	-	-	-	-	-	-	-
1	579	-	818	-	-	-	-	-	-	-

C = Coarse Thread

F = Fine Thread

\* = Torque values for #6 through 1/4 are lb./in. All others are lb./ft.

NOTE

Decrease the torque by 20% when using thread lubricant  
The torque tolerance is  $\pm$  on torque values.

+

C2000/9905

## HYDRAULIC TORQUE REQUIREMENTS

### HYDRAULIC TORQUE REQUIREMENTS

Refer to the following chart for torque values on all hydraulic hoses and fittings.

Nominal SAE Dash Size	O-Ring Face Seal End		SAE O-Ring Boss End	
	Thread Size Inch	Swivel Nut Torque	Thread Size Inch	Str. Fitting or Locknut Torque
		LB-FT		LB-FT
-3	*	*	3/8-24	8-10
-4	9/16-18	10-12	7-16-20	14-16
-5	*	*	1/2-20	18-20
-6	11/16-16	18-20	9/16-18	24-25
-8	13/16-16	32-35	3/4-16	50-60
-10	1-14	46-50	7/8-14	72-80
-12	1 3/16-12	65-70	1 1/16-12	125-135
-14	1 3/16-12	65-70	1 3/16-12	160-180
-16	1 7/16-12	92-100	1 5/16-12	200-220
-20	1 11/16-12	125-140	1 5/8-12	210-280
-24	2-12	150-165	1 7/8-12	270-360





































\* O-Ring face seal type end not defined for this tube size.

#### NOTE

**Parts must be lightly oiled with hydraulic fluid.**

C-2002

**THESE SYMBOLS IDENTIFY CONTROLS, DISPLAYS/FEATURES, AND SAFETY SYMBOLS ON THE MACHINE.**

	Battery Charger		Scrub Brush Down Heavy Pressure
	Choke		Squeegee Down & Vacuum On
	Fan On		Squeegee Up & Vacuum Off
	Filter Shaker On		Squeegee Up & Vacuum On
	Forward/Reverse		Solution Tank Low
	Headlights		Solution Flow Control
	Hopper Dump		Throttle
	Hopper Return		Read Machine Manual Before Operating or Servicing
	Horn		No gas or combustibles in tank
	Main Broom & Side Broom Up		Keep Away From Flames/ NO Smoking
	Main Broom & Side Broom Down		Wear Eye Protection
	No Step		Electrical Hazard
	Off		Stay Clear
	On		Moving Fan Blade
	Power		Pinch Point/Crush Hazard
	Recovery Tank High		Cover or Hopper Could Close/ Engage Support
	Scrub Brush Down & On		Turn Key Off/Lock Wheel Before Leaving Seat
	Scrub Brush Up and Off		WARNING! / ATTENTION!

**ORDERING PARTS**

**Parts may be ordered from Clarke authorized distributors. Record the information from the serial number plate to avoid delays in filling your order.**

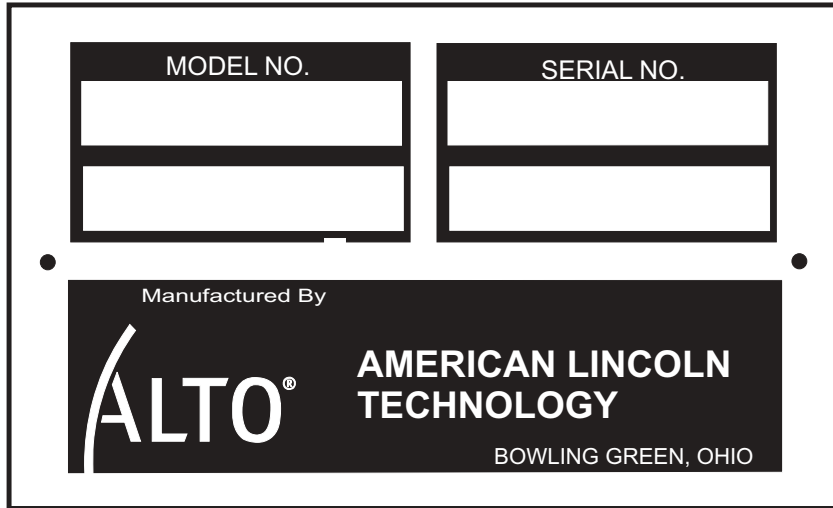

1. Use the model number, catalog number, and serial number when ordering.
2. Give the part number, description, and quality of parts needed.
3. Give shipping instructions for either freight, UPS, or parcel post.

Parts and supplies listed in this manual can be ordered from the following address:

<b>Clarke</b>	<b>Clarke Distributor</b>
2100 Highway 265 Springdale, AR 72764 1-800-253-0367	

**MACHINE CATALOG NUMBERS**

- 505-947 ENCORE MAX 34" (330 AH) w/POLYPROPYLENE SCRUB BRUSHES
- 505-948 ENCORE MAX 34" (330 AH) w/LITE GRIT SCRUB BRUSHES
- 505-949 ENCORE MAX 34" (330 AH) w/PAD DRIVER ASSEMBLY
- 505-950 ENCORE MAX 34" (370 AH) w/POLYPROPYLENE SCRUB BRUSHES
- 505-951 ENCORE MAX 34" (370 AH) w/LITE GRIT SCRUB BRUSHES
- 505-952 ENCORE MAX 34" (370 AH) w/PAD DRIVER ASSEMBLY
- 505-953 ENCORE MAX 38" (330 AH) w/POLYPROPYLENE SCRUB BRUSHES
- 505-954 ENCORE MAX 38" (330 AH) w/LITE GRIT SCRUB BRUSHES
- 505-955 ENCORE MAX 38" (330 AH) w/PAD DRIVER ASSEMBLY
- 505-956 ENCORE MAX 38" (370 AH) w/POLYPROPYLENE SCRUB BRUSHES
- 505-957 ENCORE MAX 38" (370 AH) w/LITE GRIT SCRUB BRUSHES
- 505-958 ENCORE MAX 38" (370 AH) w/PAD DRIVER ASSEMBLY



# SAFETY PRECAUTIONS

---

## HAZARD SERIOUSNESS LEVEL

Signal words (DANGER, WARNING and CAUTION) are used to identify levels of hazard seriousness. The degree of severity is based on the likely consequences of human interaction with the hazard.

 **DANGER**

To warn of immediate hazards which will result in severe personal injury or death.

 **WARNING**

To warn of hazard or unsafe practices which could result in severe personal injury.

 **CAUTION**

To warn of hazards or unsafe practices which could result in minor personal injury.

 **ATTENTION**

To warn of unsafe practices which could result in extensive equipment damage.

 **NOTE**

To give important information or to warn of unsafe practices which could result in equipment damage.

For the safe operation of this machine, read and understand all WARNINGS, CAUTIONS AND NOTES.

## PERSONAL SAFETY

- Read this manual carefully. The following information signals potentially dangerous conditions to the operator or equipment. Know when these conditions can exist then take necessary steps to train machine operating personnel.
- Dress appropriately; loose clothing, jewelry and other accessories may get caught in the machine and cause physical injury.
- Wear OSHA/NIOSH protective eye wear or prescription glasses to protect eyes.
- Wear appropriate gloves when filling and/or draining tanks.
- Before operating machine, test brake mechanism, lights and back up alarm (if applicable).
- Observe maintenance schedule guidelines to assume optimal safe operation of the machine.
- Be aware of pinch points that exist on the machine.
- Do not operate machine if you are tired, upset, ill on medication or intoxicated.
- Be completely aware of your surroundings. STOP, LOOK, and LISTEN for other employees walking in or around your cleaning area.

## MACHINE SAFETY

- Operator must be properly trained to operate machine.
- Read this manual before operating machine
- Familiarize yourself with all components and safety features.
- Do not operate machine unless it is completely assembled.
- Do not use machine other than intended use.
- Report damages or maintenance problem immediately. Do not use machine until it has been repaired.
- Repairs should be done by authorized personnel.
- For storage, keep machine in a building.
- This machine is not at tow truck and should not be used for towing.
- Do not use this machine as a step or furniture.
- Do not operate machine on public highways, gravel, sand, grass and other unsafe surfaces.

- Be careful when operating the machine on a ramp or incline. Do not operate machine on incline greater than 8° or longer than 100'. Always move slowly on a ramp. Do not turn this machine on a ramp.
- Do not stop and leave this machine on a ramp. Always stop the machine on a level surface, put the power switch in the on position.
- To prevent injury, and damage to the machine, do not lift the machine or move it to an edge of a stair or loading dock.
- Turn off machine when unattended, filling, fueling or doing maintenance on machine (if applicable).
- Do not operate machine near flammable materials, fire or explosion may occur.
- Solution or recovery tank should not be filled with fuel or chemicals.
- Read label on cleaning solutions to verify it is safe for machine.
- Use a cleaning concentrate recommended by the chemical manufacturer.
- Water solutions or cleaning materials used can leave wet areas on floor surfaces causing dangerous conditions for the operator or other persons. Always put CAUTION signs near area you are cleaning.
- Use care when reversing machine.
- Always empty the solution tank and recovery tank before doing maintenance.
- Unplug the battery first to prevent possible injury when servicing a machine.
- Lead acid batteries generate gases, which can cause an explosion. Keep sparks and flames away from batteries. NO SMOKING. Charge batteries only in area with good ventilation.
- Always wear eye protection and protective clothing when working near batteries. Remove all jewelry. Do not put tools or other metal objects across the battery terminals, or the tops of batteries.
- Keep electrical parts of the machine dry.
- Make sure that all labels, decals, warnings, cautions and instructions are fastened to the machine. Get new labels and decals from American-Lincoln.

## SPECIFICATIONS

---

### POWER SUPPLY

Encore Max (34")	36 volt (6-6 volt batteries) 340 AH or 370 AH
Encore Max (38")	36 volt (6-6 volt batteries) 340 AH or 370 AH
Encore Max (34" & 38")	For machine to operate properly, voltage reading should fall within the 32-40V range

### CHARGER

Encore Max (34" & 38")	36 Volt output, 115V/60Hz or 230V/50Hz Input
------------------------	--

### MOTORS, VACUUM

1 HP (.74 kw), 3 stage, tangential discharge

### MOTORS, BRUSH

1.7 hp (1.3kw)

### MOTOR, DRIVE

1.5 hp (1.1kw)

### WHEELS

(1) Front 12.0" (31.8 cm) (2) rear 12.0" (31.8 cm)

### BRUSH SIZE

Encore Max (34")	2-17" (43.2 cm) DIA.
Encore Max (38")	2-19" (48.3 cm) DIA.

### CLEANING PATH

Encore Max (34")	34" (86.4 cm)
Encore Max (38")	38" (96.5 cm)

### BRUSH SPEED

300 RPM

### SOLUTION TANK

45 gallon (171 liter)

### RECOVERY TANK

45 gallon (171 liter)

### SPEED, TRANSPORT

5 MPH

### SPEED, SCRUBBING

2.5 MPH

### TURN RADIUS

56" (142.2 cm)

### U-TURN AISLE WIDTH

80" (203.2 cm)

### CLEANING RATE

Encore Max (34")	37,000 sq. ft/hr (3426 sq. m/hr)
Encore Max (38")	42,000 sq. ft/hr (3901 sq. m/hr)

### GRADE CLEANING

3°

### GRADE TRANSPORT

8°

### LENGTH

71.5" (181.6 cm)

**WIDTH**

Encore Max (34")	Machine	33.5" (85 cm)
Brush Housings		38.0" (96.5 cm)
Squeegee		42.0" (106.7cm)

Encore Max (38")	Machine	33.5" (85 cm)
Brush Housings		41.0" (104.1 cm)
Squeegee		42.0" (106.7 cm)

**HEIGHT**

51" (129.5 cm)

**HEIGHT W/OHG**

80" (203.2 cm)

**WEIGHT**

Encore Max (34")	1800 lb. (817.2 kg)
Encore Max (38")	1820 lb. (826.3 kg)

**WARRANTY**

Machine	2 year/2,000 hours
Polydur® tanks	life of machine
Electrica Drive Line Components	3 years/3,000 hours
Batteries	18 months, prorated

# SPECIFICATIONS

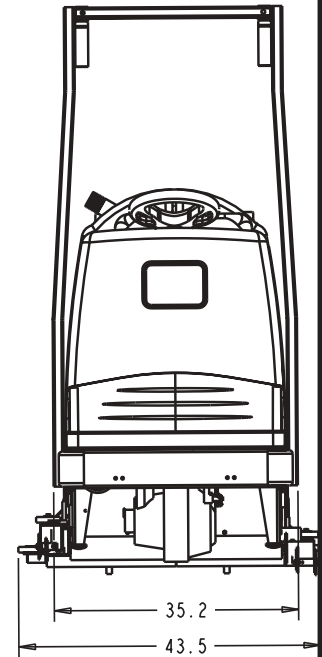
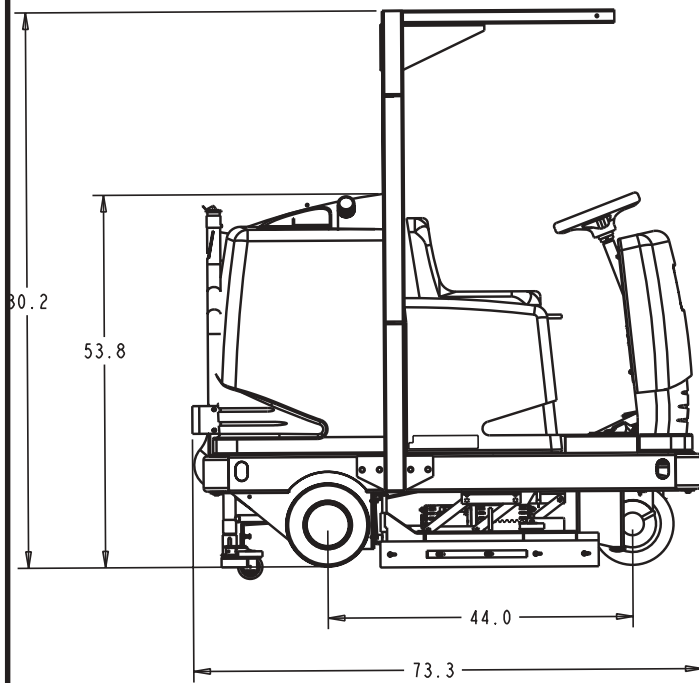



Fig. 1

Your Encore Max battery machine has been shipped complete, but do not attempt to operate without reading the following instructions:

### UNPACKING AND ASSEMBLING MACHINE

The Encore Max is shipped on a pallet covered by a plastic bag and fastened with four hold down brackets.

1. Remove plastic bag.
2. Unbolt lag screws located on each corner of machine.
- 3) Lift out bracket located on each corner of machine from slot in machine frame.
- 4) Remove rear squeegee and hose from under rear squeegee location.
- 6) Position a 11° and 36" ramp on base of pallet.

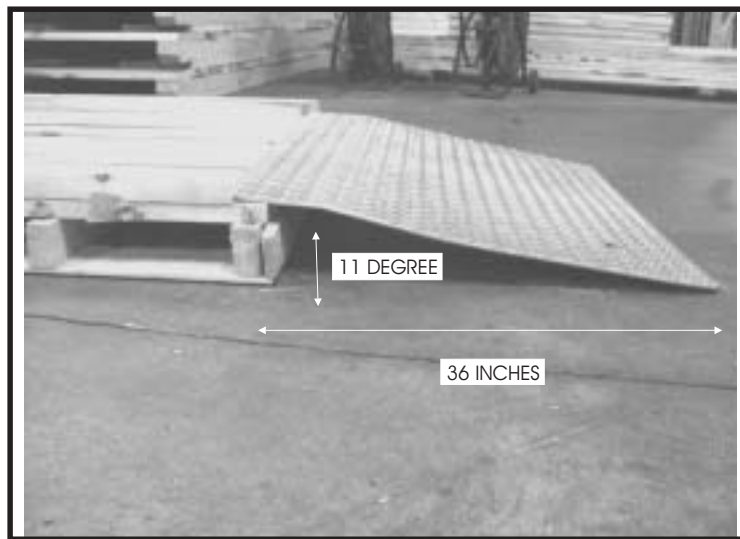

Fig. 2

## MACHINE PREPARATION



Fig. 3

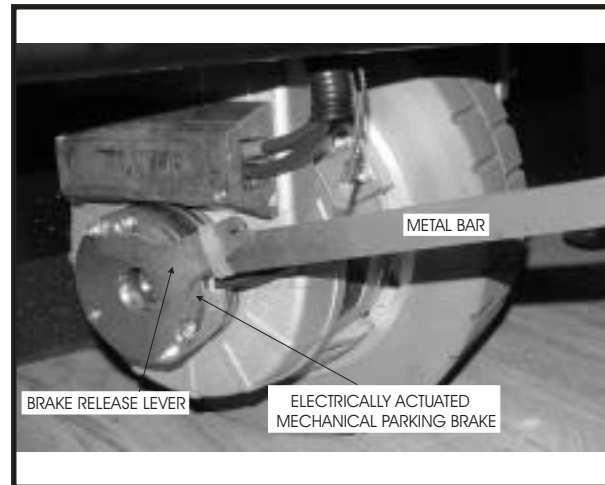

Fig. 4

 **WARNING**

**Disconnect the traction harness before towing the machine.**

- 6) The machine is shipped with a metal bar between the electrically actuated parking brake and the brake release lever to keep the electrically actuated parking brake disengaged.
- 7) Push machine down the ramp onto a flat surface.

 **WARNING**

- 8) **Remove the metal bar to engage the electrically actuated mechanical parking brake.**
- 9) Connect rear squeegee hose and install squeegee blade as shown in manual.
- 10) Remove battery charger from under the seat in battery compartment (if applicable).
- 11) Install batteries.
  - Turn the key to the "O" position
  - Lift the hinged seat and cover, then disconnect seat switch and remove seat plate.
  - Use a battery lifting device with a 150 LB. (68KG) capacity to place the batteries battery compartment.
  - Install Battery wires as shown in manual.
  - Plug the polarized connector from the battery on into the 36 Volt plug provided.
  - Install scrub brushes as shown in the manual.
  - Lower seat and cover assembly.
- 12) Charge batteries as shown in the manual. Read battery manufacturer literature for battery care and maintenance.

 **WARNING**

**Do not charge batteries on a concrete grounded surface. Hydrogen gas is formed during the charging operation and is explosive. Only charge batteries in a well ventilated area with the lid open. Avoid any smoking, open flame, or electrical sparks.**



Fig. 5

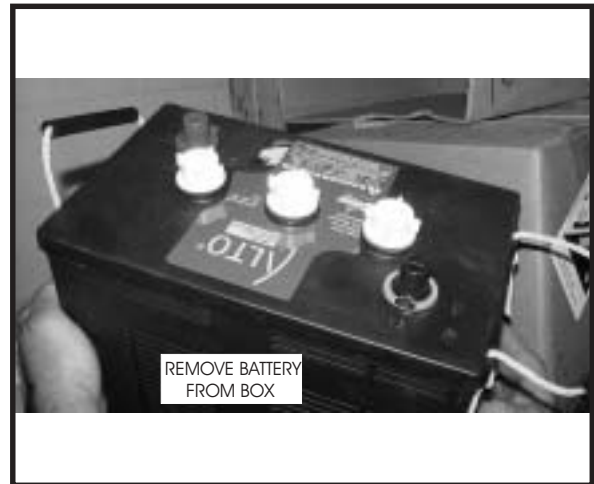

Fig. 6

**UNPACKING BATTERY**

The batteries are shipped separately in six boxes as shown in figure 5. Open the boxes on a clean work surface and lift out the battery as shown in figure 6.

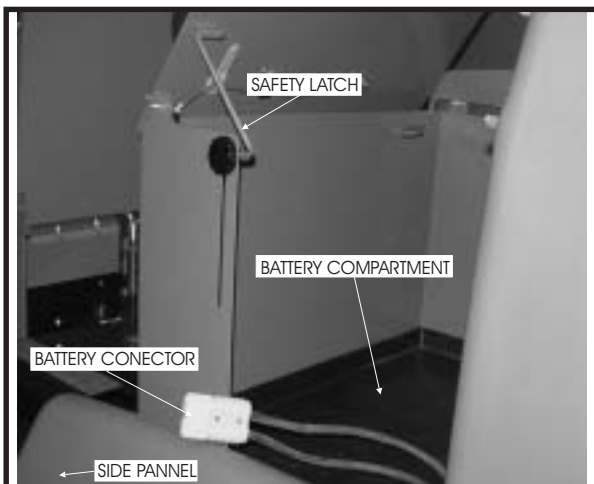

Fig. 7

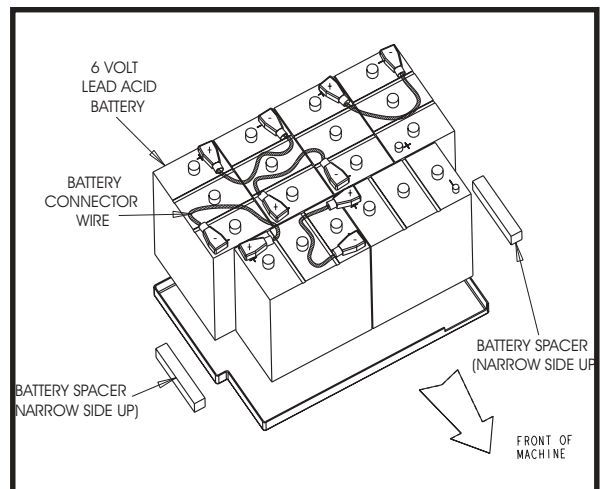

Fig. 8

**BATTERY INSTALLATION**

To install batteries lift the seat cover and secure safety latch in notch. Pull up on the side panel and remove to gain access to the battery compartment. Lower batteries using a 1000 lb. (454 KG) lifting mechanism to lift and install batteries into battery compartment placing battery spacers to stop from moving. Connect battery connector wires in series to batteries as shown in figure 8.



**WARNING**

**Do not leave charged batteries on concrete surface, they will discharge.**

## MACHINE PREPARATION

---

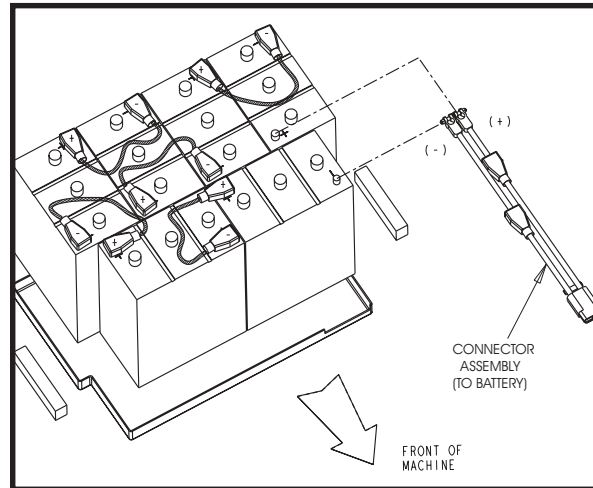

Fig. 9

Connect the battery connector assembly to battery as shown in figure 9.

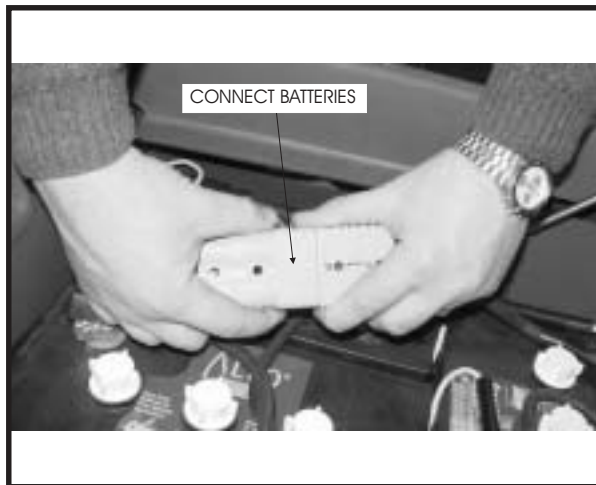

Fig. 10



Fig. 11

Plug the battery connector assembly from the battery to the machine connector assembly as shown in figure 10. Reinstall the side panel and then release the safety latch and lower the seat as shown in figure 11.

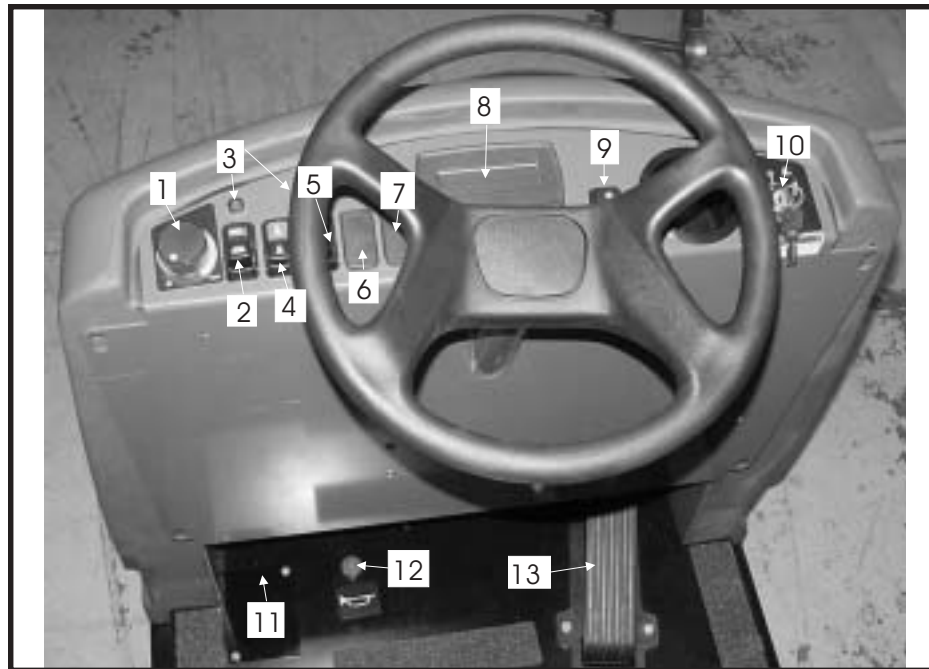

Fig. 12

1. Solution Flow Knob
2. Brush Switch
3. Low Solution Light (Left) High Recovery Light (Right)
4. Scrub Pressure Switch
5. Squeegee Vacuum Switch
6. ESP
7. Light Switch, Optional
8. LCD Display
9. Forward/Reverse Switch
10. Key Switch
11. Secondary Optional Brake Pedal (Bottom), Pedal Lock (Top)
12. Horn Button, Optional
13. Foot Throttle

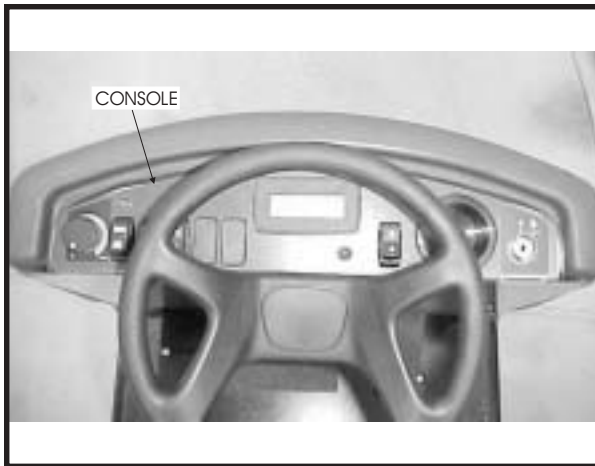

Fig. 13

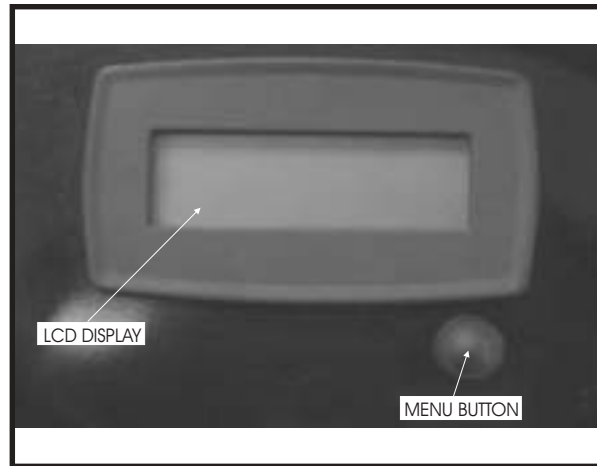

Fig. 14

**LCD DISPLAY SCREEN CONTROL BUTTON**

The Encore Max is equipped with an LCD display allowing the operator to monitor machine operation. The LCD display button is located in the center of the console to the right under the display. Pushing on the menu button enables the operator to view screen functions and monitor machine status and operation. When the key switch is turned on, screen 1 will automatically be displayed. Pressing the menu button will allow you to review screens 2 and 3.

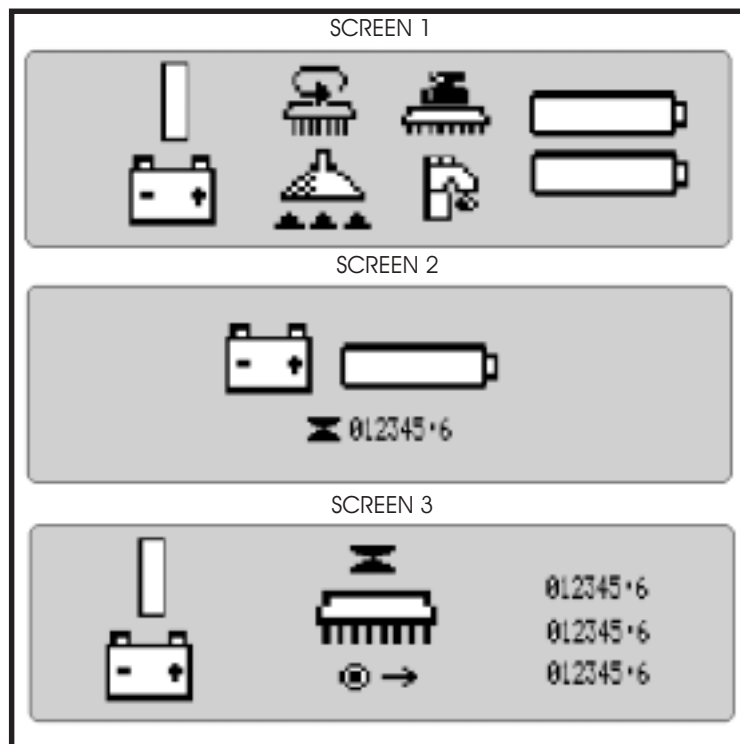

Fig. 15

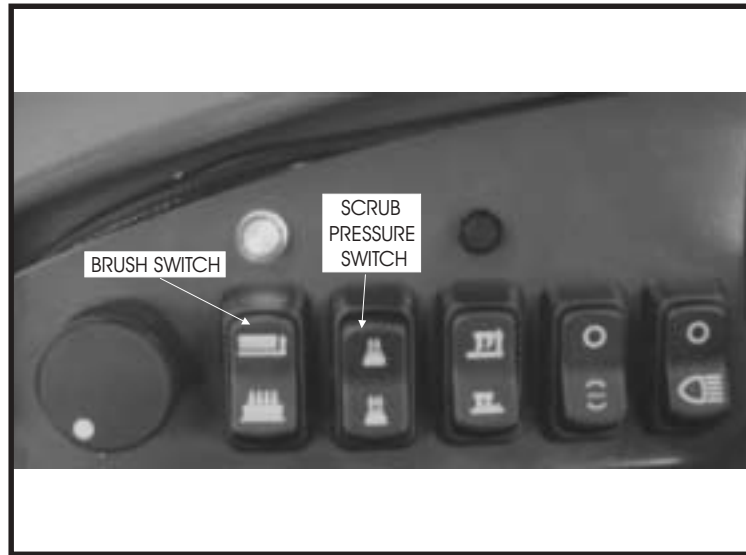

Fig. 16

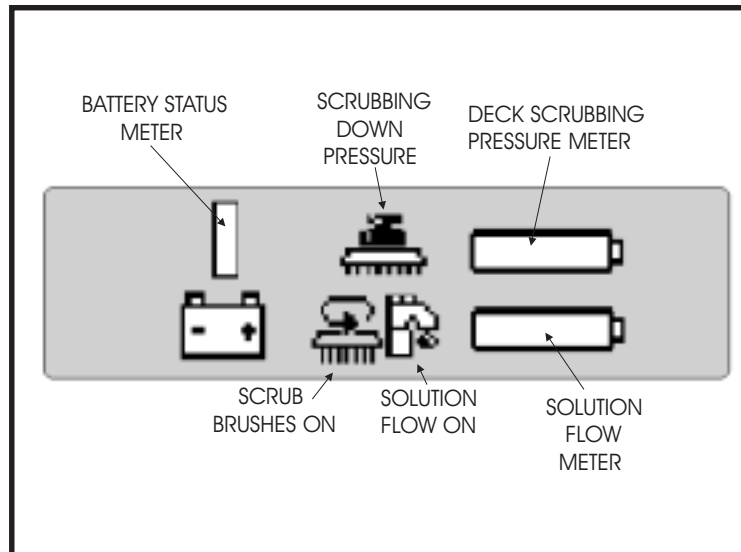

Fig. 17

**SCRUB BRUSH SWITCH**

The scrub brush switch is located on the left side of the console to right of the solution control knob as shown in figure 16. Pushing the scrub brush switch to up position will raise the scrub deck to the top position, the scrub brushes will stop rotating, the water solenoid will de-energize and solution flow will stop. Pushing the scrub brush switch down will lower the scrub deck to the set down pressure. The squeegee will lower and the vacuum will activate. When the scrub brush and squeegee are on, they will be displayed as shown in figure 17. The brushes will not rotate until the foot throttle is depressed. Releasing the foot throttle will raise the scrub deck to the top position and the brushes will stop rotating.

**SCRUB PRESSURE SWITCH**

The scrub pressure switch is located on the left side of the console between scrub brush switch and the squeegee/vacuum switch as shown in figure 16. Pushing the scrub pressure switch up selects the next highest scrub setting available, increasing pressure. Selected pressure is displayed as a bar on the LCD control panel. Pressing the scrub pressure switch down selects the next lowest setting available, decreasing pressure as shown in figure 17.



Fig. 18

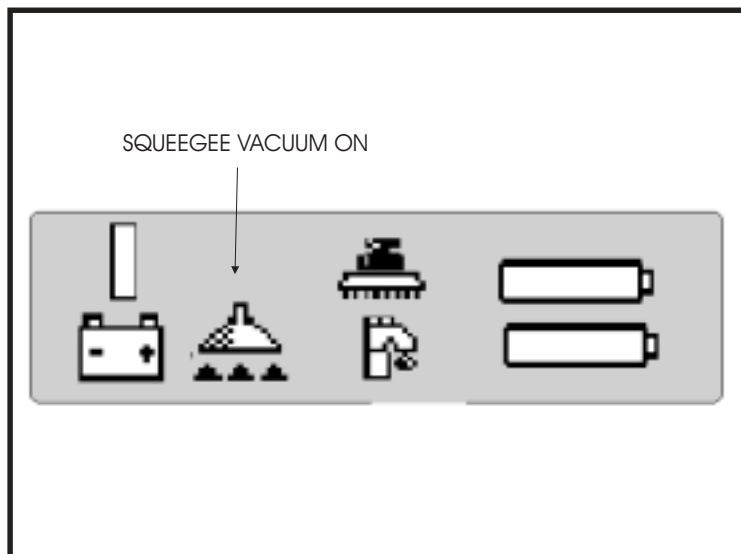

Fig. 19

### **SQUEEGEE/VACUUM SWITCH**

The squeegee vacuum switch is located on the left side of the console to the right of the scrub brush switch as shown in figure 18. Pushing the squeegee/vacuum switch up raises and turns off the vacuum. Pushing the squeegee/vacuum switch down lowers the squeegee and turns on the vacuum. When the vacuum is on, it is displayed as shown in figure 19. Pressing down on the foot throttle with the forward/reverse switch in the reverse position will raise the squeegee when it is down. The vacuum will turn off in 15 seconds after the squeegee is raised.



Fig. 20

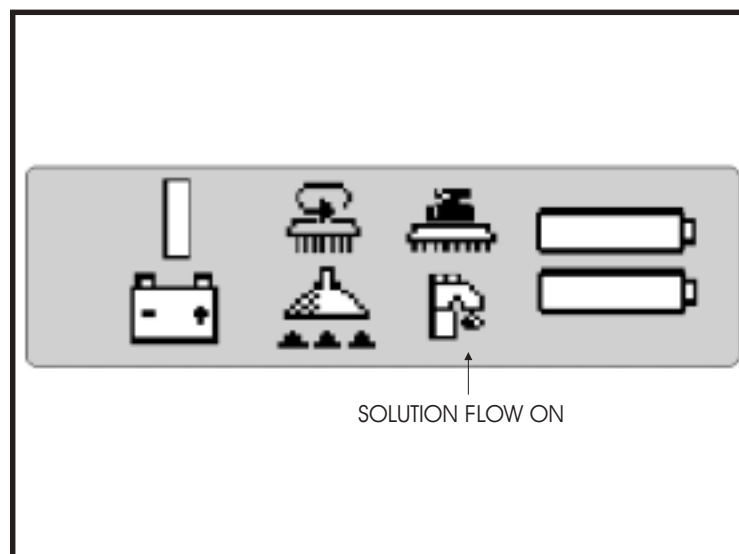

Fig. 21

**SOLUTION FLOW CONTROL KNOB**

The solution flow control knob is located on the console to the left of the scrub brush switch as shown in figure 20. When solution flow is on, the flow rate will be displayed as a bar shown in figure 21. The solution control knob gives an output of 0-3 GPM. Turning the knob clockwise increased the amount of solution deposited. Turning the knob counterclockwise decreases the amount of solution deposited. Solution flow will stop when the brushes are off or the key is in the off position.

**LOW SOLUTION INDICATOR LIGHT**

The low solution amber indicator light is located on the left side above the switches on the console to the left of the high recovery indicator light as shown in figure 20. When the low solution indicator light illuminates the solution tanks need to be filled.

**HIGH RECOVERY INDICATOR LIGHT**

The high recovery red indicator light is located on the left side above the switches on the console to the right of the low solution indicator light as shown in figure 21. When the high recovery indicator light illuminates the recovery tank is full and needs to be drained and cleaned out.

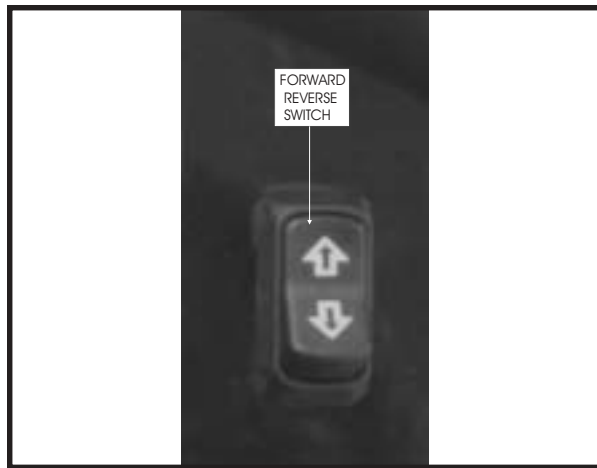

Fig. 22

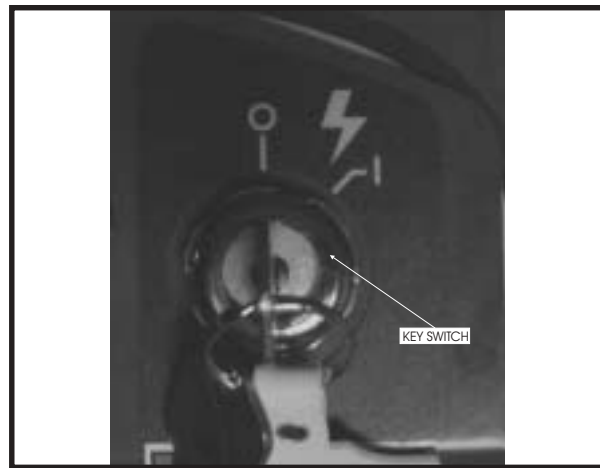

Fig. 23

### **FORWARD/REVERSE SWITCH**

The forward/reverse switch is located on the right side of the console to right side of the steering wheel as shown in figure 22. Pushing the forward/reverse switch up will result in the machine moving forward when the foot throttle is depressed. Pushing the forward/reverse lever switch down will result in the machine moving backward when the foot throttle is depressed.

### **KEY SWITCH**

The key switch turned to the right, the "I" position, will activate all machine systems as shown in figure 23.

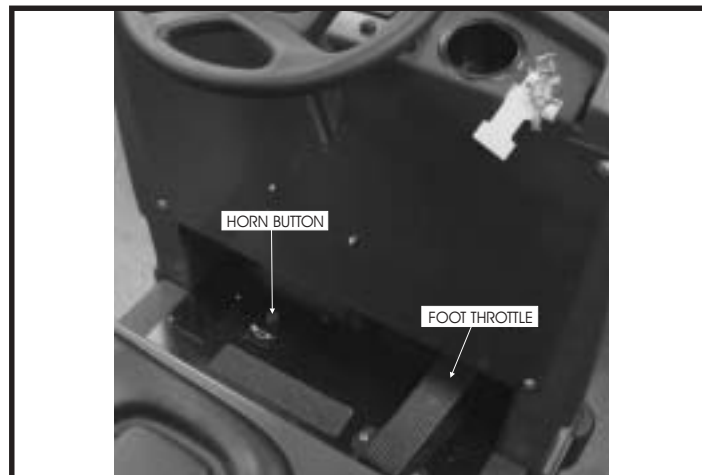

Fig. 24

### **FOOT THROTTLE**

The foot throttle is located on the floor on the right side as shown in figure 24. Pressing the foot throttle pedal down sets the machine in forward or reverse motion, the direction depending on the position of the forward/reverse switch.

### **HORN BUTTON**

The horn button is located on the floor of the operator's compartment to the left of the optional parking brake pedal as shown in figure 24. Pressing the button with the left foot will activate the horn.

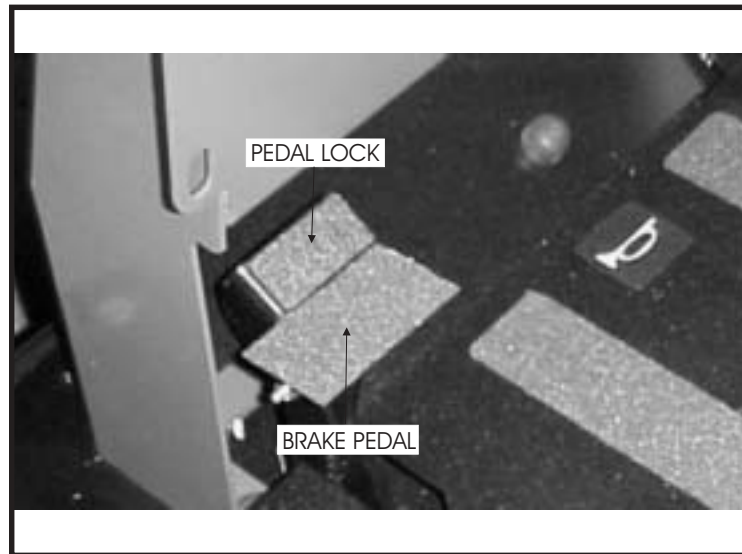

Fig. 25

**SECONDARY PARKING BRAKE (OPTION)**

The machine is equipped with an electrically actuated mechanical parking brake on the front drive wheel that is automatically engaged when the key is turned off or the drive wheel stops rotating. A secondary, mechanically actuated parking brake is available as an option as shown in figure 25. To set the secondary parking brake, press down the brake and then press the lock on the upper portion of the pedal. To unlock the parking brake, push on the upper portion of the pedal lock to release it. The foot brake is not a method for slowing machine travel or for stopping under normal conditions. This is accomplished by releasing the foot throttle.

## CONTROLS



Fig. 26

### ESP (OPTION)

The ESP switch is located on the left side of the console in between the squeegee/vacuum switch and the light switch. The ESP switch transfers water from the recovery tank through a filter and into the solution tank. When the switch is in the down position the pump will operate when the high recovery light is illuminated. Clean the filter in the recovery tank when the tank is emptied.



### NOTE

**Do not place clean water in the recovery tank when using the ESP option, the solution tank could become overfilled during operation.**

### LIGHT SWITCH (OPTION)

The light switch is located on the left side of the console to the left of the steering wheel as shown in figure 26. Pushing the light switch to the up position will illuminate the optional light located in the center on the front of the machine. Pushing the light switch to the down position will turn the light off.

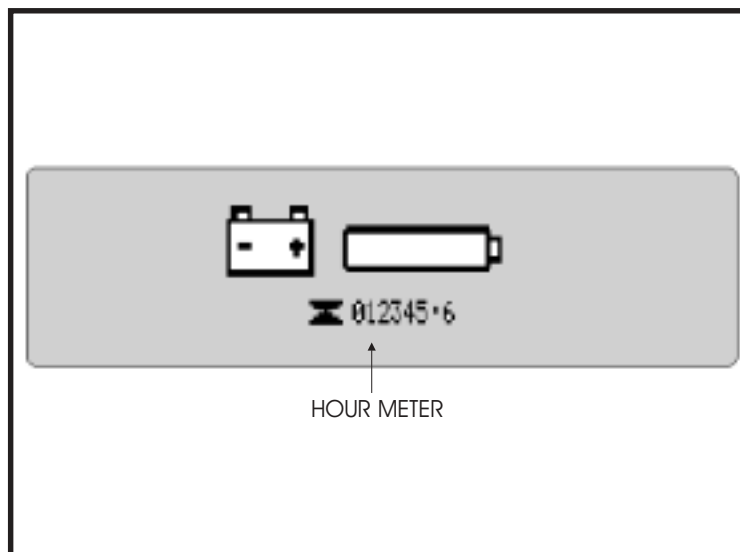

Fig. 27

### HOUR METER

The hour meter is activated when the key switch is in the “on” position. Screen 2 on the LCD display shows total hours and panel screen display 3 shows total hours, brush hours and traction hours. This is useful for determining service intervals.

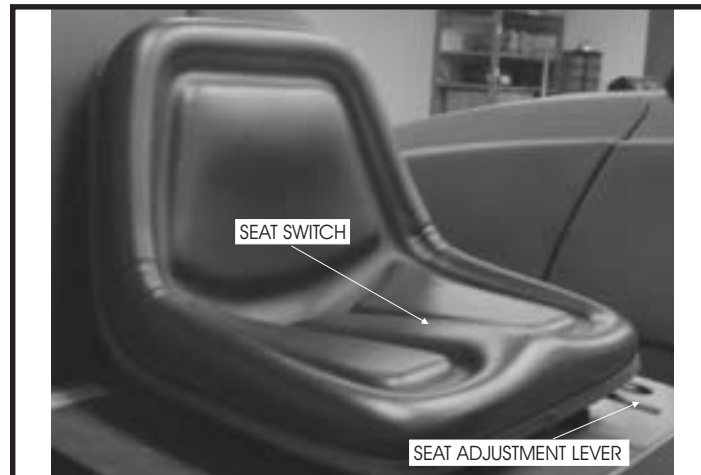

Fig. 28

**SEAT ADJUSTMENT LEVER**

This lever is located on front to the seat to the left allowing the seat to be moved forward and back as shown in figure 28.

**SEAT SWITCH**

The seat switch is a interlock safety switch located on the underside the seat and is activated by the operator's body weight while seated. The machine will stop immediately if there is no operator present in the seat.



Fig. 29

**PRE SWEEP (OPTION)**

The sweeper is designed to turn the broom on as it is lowered. To lower the broom release hand lever on right side.

## OPERATING INSTRUCTIONS

---



### Note

Before starting, perform the pre-start checks.

### PRE-START CHECKLIST

1. Check controls for proper operation.
2. Make sure all controls are in the off position
3. Be sure foot throttle is in the neutral position
4. Check all flaps for damage or wear
5. Check scrub brushes for wear
6. Fill solution tank with water and detergent



Fig. 30

### TO FILL SOLUTION TANK

Remove the solution lid located on the back right side of the machine as shown in figure 30. Fill tank with 40 gallons of water and the correct mixture of American Lincoln Commercial cleaner for the job on hand, first making sure that the solution control knob is "OFF." Place the lid back on the solution tank.

### TO START MACHINE

1. Release secondary parking brake (if equipped).
2. Turn key to "I" position.

### TO TRANSPORT MACHINE

1. Make sure the brushes and squeegees are in the up or raised position with all other controls in the off position.
2. Push the forward/reverse switch to desired position (up for forward and down for reverse)
3. Push down on the foot throttle to obtain desired travel speed, release foot throttle to stop.



### WARNING

**Do not turn the steering wheel sharply when the machine is in motion. The sweeper is very responsive to movement of the steering wheel. Do not make sudden turns.**

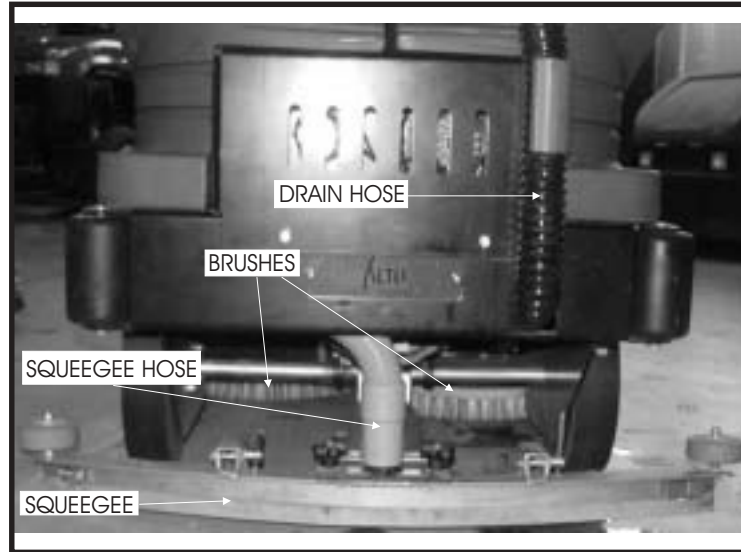

Fig. 31

#### **TO BEGIN THE CLEANING OPERATION**

1. Lower brushes to the desired position.  
SCRUB DECK = NORMAL RANGE OR HEAVY
2. Place the squeegee switch in the lower position.  
SQUEEGEE BLADE = LOWER
3. Move solution control knob to the desired setting and begin operation.

#### **SCRUBBING THE AVERAGE FLOOR WITH LIGHT TO MEDIUM SOILAGE**

In this operation, cleaning is accomplished in one pass, with simultaneous solution feed, scrubbing and dirty water pick up. The rate of solution feed and the speed of travel required will vary with floor condition. This knowledge will come with operator experience.

#### **SAFETY FEATURES**

**SEAT SAFETY SWITCH** - Machine will not move and parking brake will set if this switch is not activated.

**SPEED INTERLOCK** - Maximum machine speed will be reduced while scrub brushes are in use.

**BRUSHES OFF IN NEUTRAL** - Scrub brushes automatically disengage when machine is idle.

**PARKING BRAKE INTERLOCK** - Parking brake will automatically set when foot pedal is released.

**AUTOMATIC RECOVERY VACUUM SHUT-OFF** - Vacuum fans will shut down when recovery tank is full.

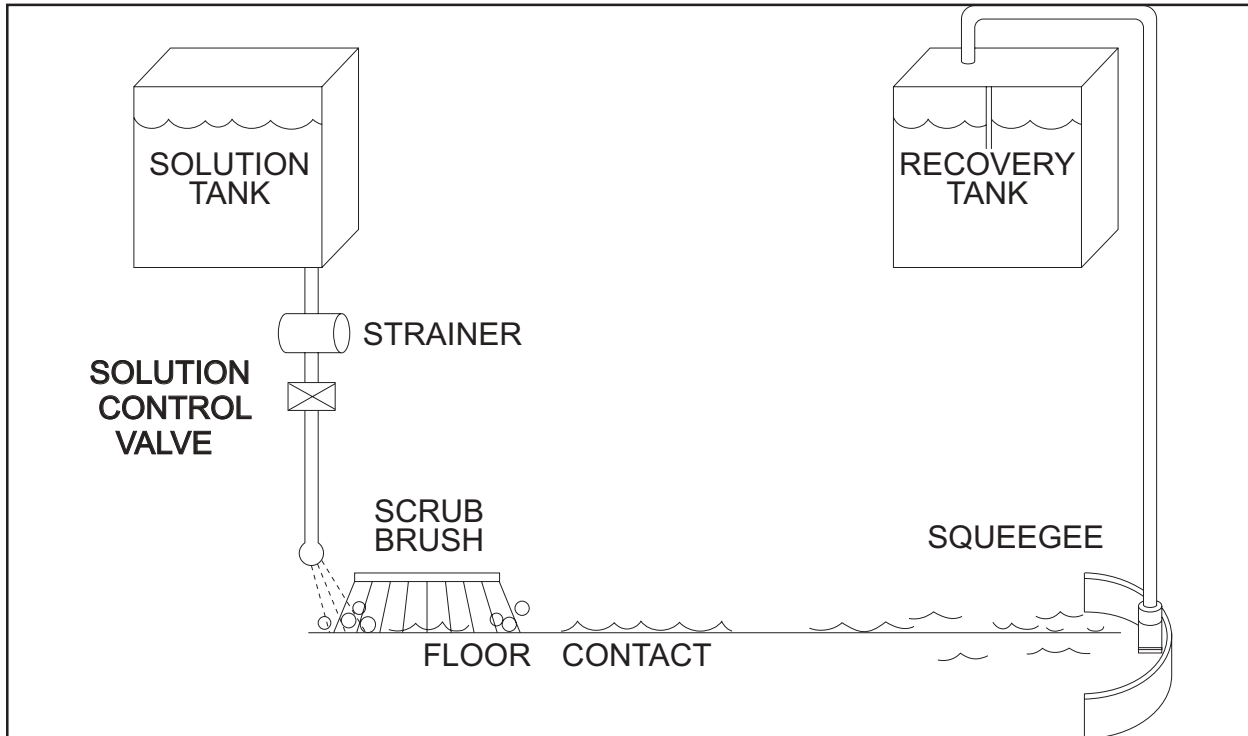

Fig. 32

### THE NON-RECYCLING OR STANDARD SCRUBBING MODE

During the scrubbing process, detergent solution water from the solution tank is fed to the solution line. There it is fed to the floor where two disc scrubbing brushes work to dislodge soil. After scrubbing, the dirty solution is vacuumed from the floor and discharged into the recovery tank.

Sensors in each tank will indicate, by lights on the control panel, when the water in the solution tank is too low or when the water in the recovery tank is too high.

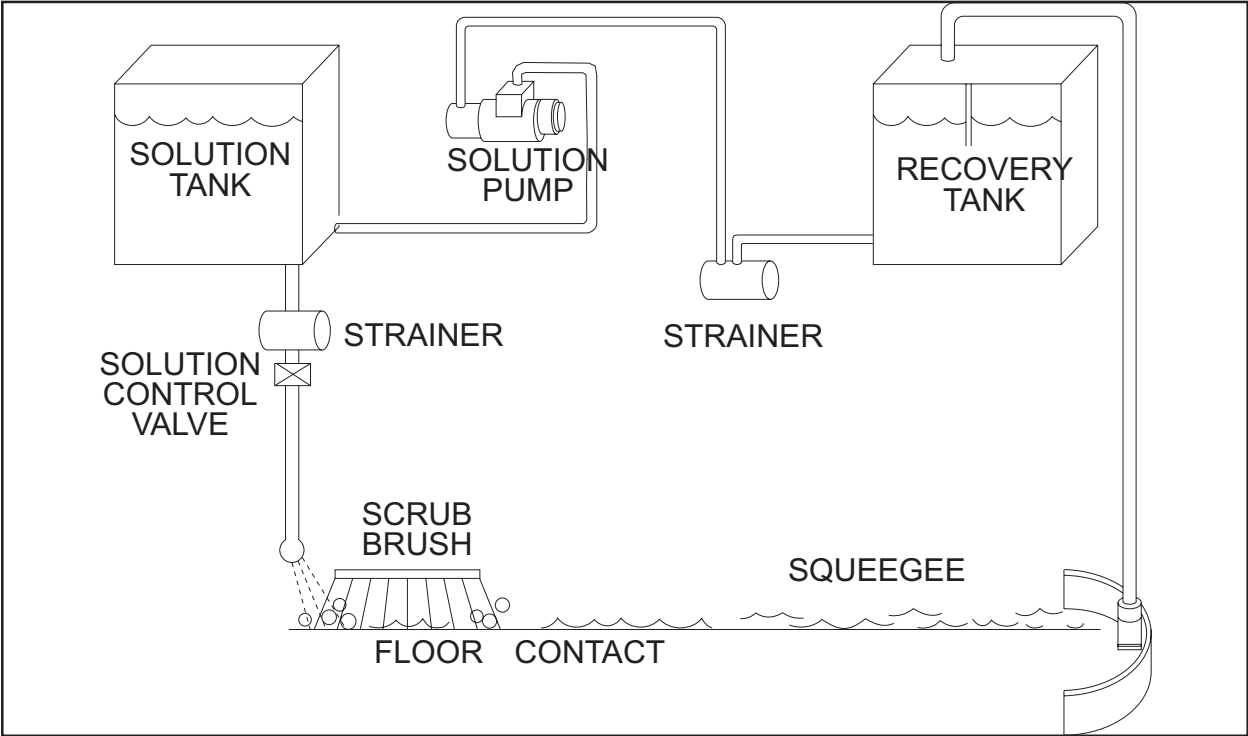

Fig. 33

**ESP OPERATING MODE**

During the scrubbing process, filtered water from the solution tank is fed to the solution line and then to the floor where two disc scrubbing brushes work to dislodge soil. After scrubbing, the dirty solution is vacuumed from the floor and discharged into the recovery tank. At intervals, a float switch activates the recycling pump, which sends filtered solution from the recovery tank to the solution tank.

## OPERATING INSTRUCTIONS

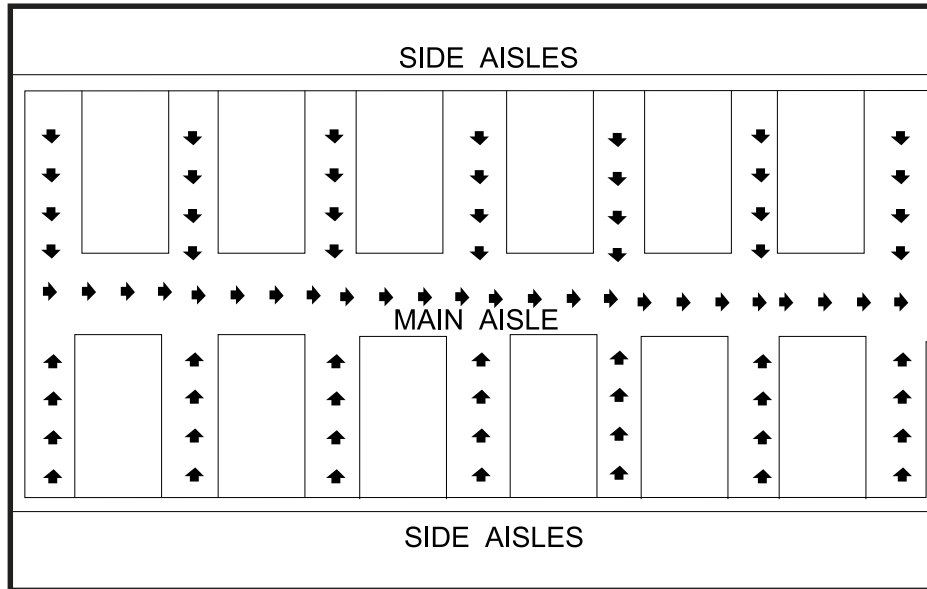

Fig. 34

### SCRUBBING PATH

- Scrub in straight paths. Do not bump posts. Do not scrape the sides of the machine.
- When the machine is in motion, do not push the directional/speed control pedal all the way forward. This is the same as starting in “high” and will put a strain on the motor and drive system.
- Plan your sweeping and scrubbing in advance. Try to arrange long runs with minimum stopping and starting. Sweep debris from narrow aisles out into main aisle ahead of time. Do an entire floor, or section at on time.
- Pick up oversize debris before sweeping.
- Allow a few inches of overlap of sweep and scrub paths. This will eliminate leaving dirty patches.
- Allow a few inches of overlap of sweep and scrub paths. This will eliminate leaving dirty patches.
- Don't turn steering wheel to sharply when machine is in motion. The machine is very responsive to movement of the steering wheel; so avoid sudden turns.
- Try to follow as straight a path as possible. Avoid bumping into posts or scraping the sides of the machine.
- When placing the machine in motion, avoid slamming the directional control pedal all the way forward suddenly. This is equivalent to starting out in “HIGH” and puts needless strain on the drive system. Periodically, turn the sweeping broom end for end to prevent the bristles from “settling” in one direction.

### TO STOP THE CLEANING OPERATION

Discontinue the cleaning operation when the low solution light or the high recovery light illuminates, this indicates the solution tank is empty or recovery tank is full. Discontinue the scrubbing cycle, put all controls in the forward position for transport and drive to the drain area.



#### NOTE

After stopping, perform these post operation checks.

## POST OPERATION CHECKLIST

Check Battery Condition and recharge, if necessary.

1. Check all flaps for wear, damage and adjustment.
2. Drain and clean recovery tank.
3. Clean recovery tank screen and float.
4. Check scrub brushes for wear or damage.
5. Check rear and side squeegee for wear, damage and adjustment.

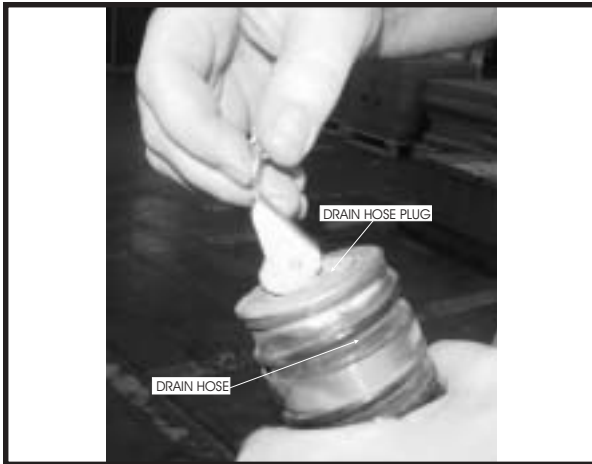

Fig. 35



Fig. 36



Fig. 37

## TO DRAIN RECOVERY TANK

The drain hose for the recovery tank is located on the back of the machine. To drain the tank, remove and lower the hose and place in a suitable floor drain as shown in figure 37. Open the drain hose plug as shown in figure 35 and 36.

### IMPORTANT

**Improper discharge of wastewater will damage the environment and is illegal. The U.S. Environmental Protection Agency has established certain regulations regarding discharge of wastewater. The local city and state regulations regarding wastewater discharge may be in effect in your area. Understand and follow the regulations in your area. Be aware of the environmental hazards associated with the substances you dispose of.**

# OPERATING INSTRUCTIONS



Fig. 38



Fig. 39

When the draining operation is completed, flush the recovery drain hose as shown in figure 38. Clean the recovery tank and recovery tank screen as shown in figure 39. Close the drain hose plug, close recovery tank lid and clip the drain hose into place.

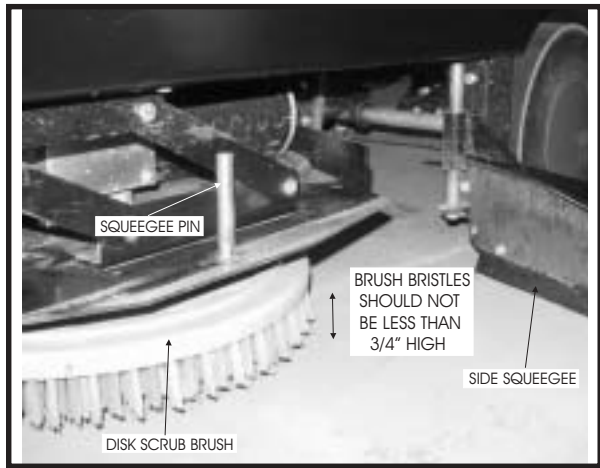

Fig. 40

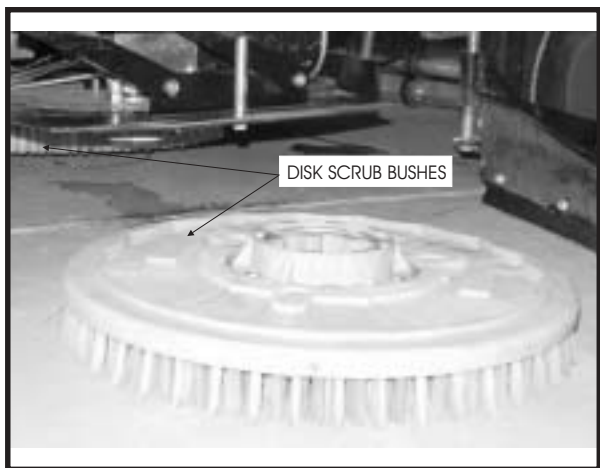

Fig. 41

Inspect the disc brushes and replace when bristles are reduced to 3/4 inch length as shown in figure 40 and 41. To order replacement brushes, see scrub brush options in this manual.



Fig. 42

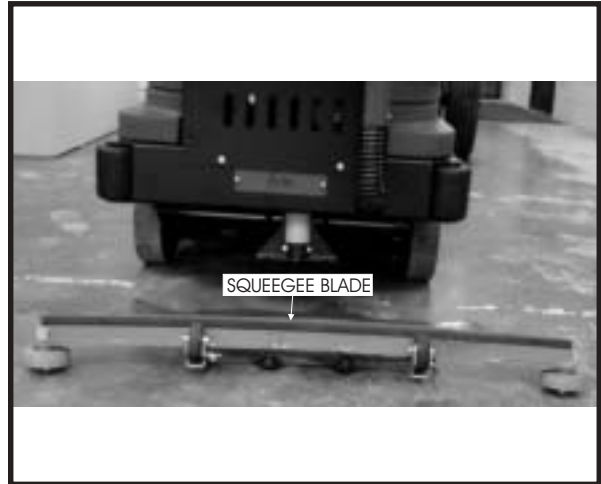

Fig. 43

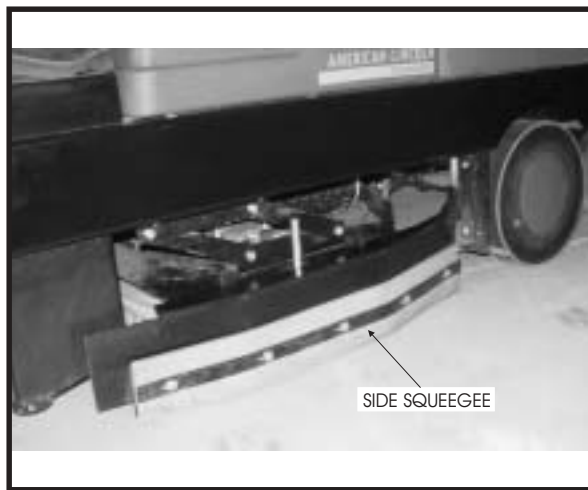

Fig. 44

Inspect the rear and side squeegee blades for wear. If the wiping edge has become rounded, remove and reinstall so the unworn edge is now the wiping edge. This process can be repeated until all four edges are worn. If the squeegee blade has become rippled, it will need to be replaced. Inspect the inner flap on the rear squeegee for wear and to ensure it has not been torn or damaged.

## OPERATING INSTRUCTIONS

---



Fig. 45

### PRE SWEEP (OPTION)

The sweeper is designed to turn the broom on as it is lowered as shown in figure 45. To lower the broom release hand lever on right side.



Fig. 46

### FILTER BAG REPLACEMENT

The filter bag should be checked every time the pre sweep is used and replaced when full as shown in figure 46.



**There is a potential risk of the bag tearing and causing premature failure to the dust control motor and the main and side broom motor.**

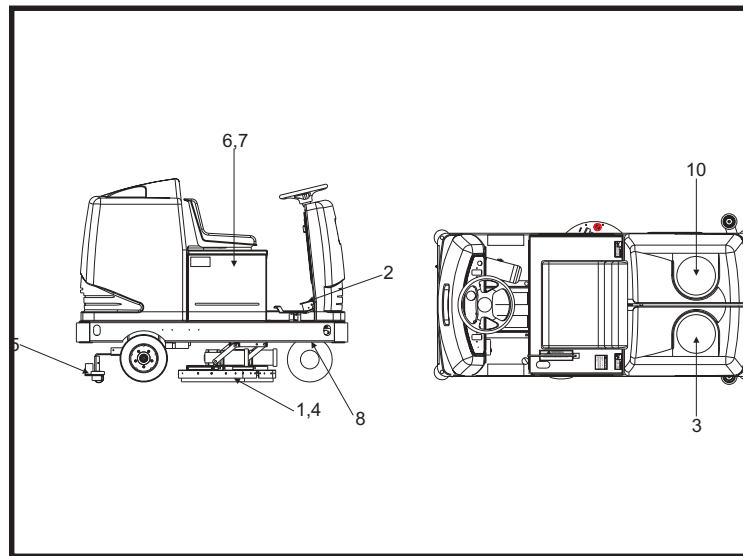

Fig. 47

**EVERY 8 HOURS or DAILY operation check and clean/adjust if necessary:**

1. All flaps for wear or damage
2. Clean recovery tank
3. Scrub brushes for wear or damage
4. Rear squeegee for wear or damage
5. Charge and check batteries

**50 HOUR MAINTENANCE CHECKLIST:**

6. Check battery electrolyte level
7. Lubricate steering bearing and pivot

**100 HOUR MAINTENANCE CHECKLIST:**

8. Clean solution tank

For service assistance, consult your local American-Lincoln Distributor, For best performance, replace worn parts with genuine American-Lincoln parts.

Refer all Maintenance and Service Requirements to Qualified Maintenance Personnel.

Do not attempt to service this machine until you have read and understood all Safety Warnings associated with the equipment you are working on.

## MAINTENANCE

---

For safety, read and follow the service precautions below. Know the hazards associated with the equipment you are working on to prevent personal injury or damage to equipment.

For service assistance, consult your nearest American-Lincoln dealer. For best performance replace worn parts with genuine American-Lincoln parts.

Refer all maintenance and service requirements to qualified maintenance personnel.

DO NOT attempt to service this machine until you have read and understand all safety warnings associated with the equipment you are working on.

### WARNING

- **Maintenance and repairs must be done by authorized personnel only.**
- **Electrical repairs must be done by authorized personnel only. Consult your American-Lincoln Authorized Service Person to do service procedures. Use only genuine American-Lincoln parts.**
- **Always park on a level surface, turn key off, and engage parking brake before working on the machine to keep it from creeping or rolling.**
- **If towing or pushing is required, disconnect motor lead located on the terminal block on the bottom of the machine.**
- **Maintenance and repairs must be done by authorized personnel only. Always empty the solution tank and the recovery tank before doing any maintenance. Keep all fasteners tight. Keep adjustments according to the specifications as shown in the Service Manual for this machine.**
- **Always wear eye protection and protective clothing when working near batteries. Do not put tools or other metal objects across the tops of the batteries. NO SMOKING.**
- **To prevent damage to the machine, and discharge across the tops of the batteries, do not fill the batteries above the bottom of the tube in each cell. Wipe any acid from the machine or the tops of the batteries. Do not add acid to a battery after installation.**
- **Always wear eye protection and protective clothing when working near batteries. NO SMOKING.**
- **Always empty the hopper and disconnect the batteries before doing any maintenance.**
- **The hopper could fall and cause serious injury. Always engage the hopper safety arm before working under the hopper.**
- **To maintain the stability of this machine in normal operation, the overhead guard, or similar equipment installed by the manufacturer as original equipment should not be removed. If it becomes necessary to remove such equipment for repair or maintenance, this equipment must be reinstalled before machine is placed back in operation.**

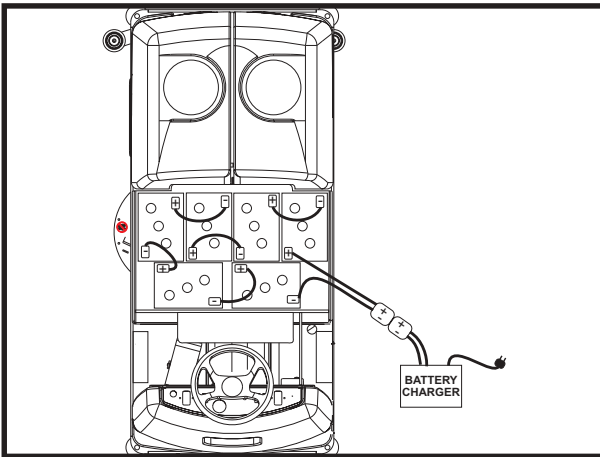

Fig. 48

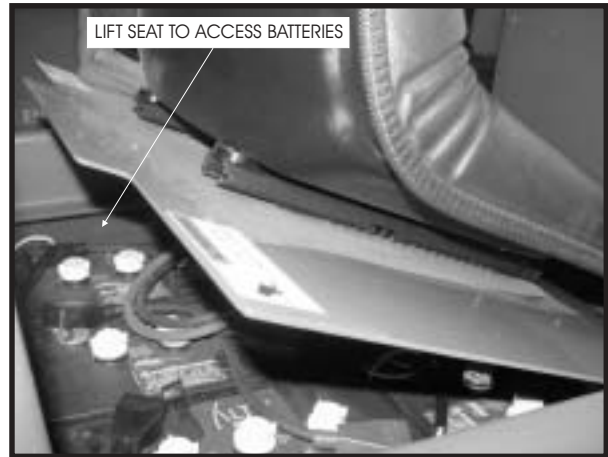

Fig. 49

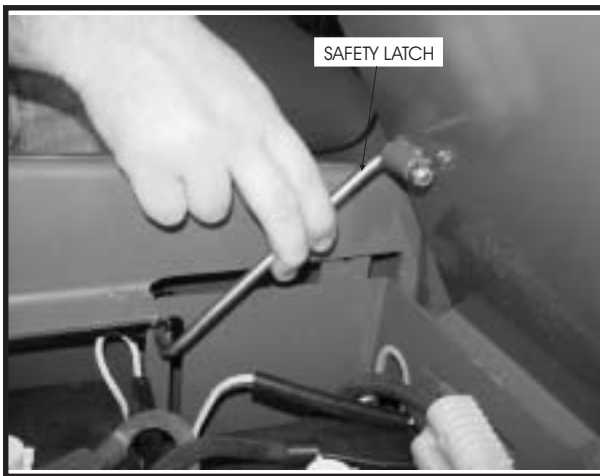

Fig. 50

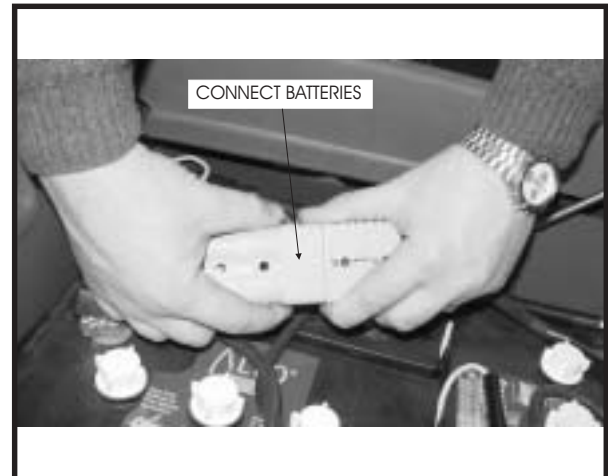

Fig. 51

**BATTERY CHARGING INSTRUCTION**

When the batteries are disconnected (i.e. charging, replacement), the microprocessor needs to be reset by turning the key switch on and raising the brush deck. When the red light comes on steady the batteries can be charged.

1. Lift seat cover, make sure safety latch is secure in notch.
2. Insert charging plug into battery receptacle.
3. Plug power cord into proper AC source.
4. Follow the charging instructions provided on the charger.
5. Maintain electrolyte level in batteries, check after charging. Add distilled water as needed.

 **WARNING**

- Do not remove the battery from the machine if there is waste in the solution tank.
- Hydrogen gas is formed during the charging operation and is explosive! Only charge batteries in a well-ventilated area with the lid open. Avoid any open flame or electrical sparks. Pulling out the charger plug, with the charger still on, will cause an arc and must be avoided.
- Batteries are heavy. Get help to lift the batteries.
- Always remove jewelry, wear protective clothing, and face protection when working near batteries.
- Lead acid batteries generate gases, which cause explosions. Keep sparks and flames away from batteries charge the batteries only in area with good ventilation. **NO SMOKING!**
- To prevent an explosion, disconnect the AC plug from the receptacle before connection or disconnection the DC plug on the charger.
- The battery box can slide off a forklift and cause severe personal injury or damage to equipment. Ensure that the battery box is properly secured to the forks of the forklift during transport, drive and stop with caution.

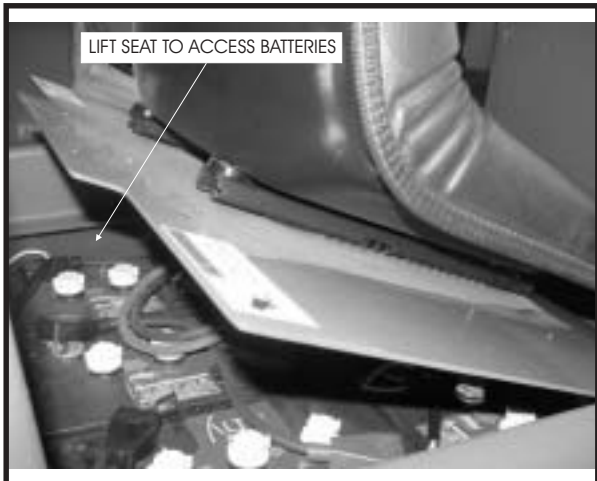

Fig. 52

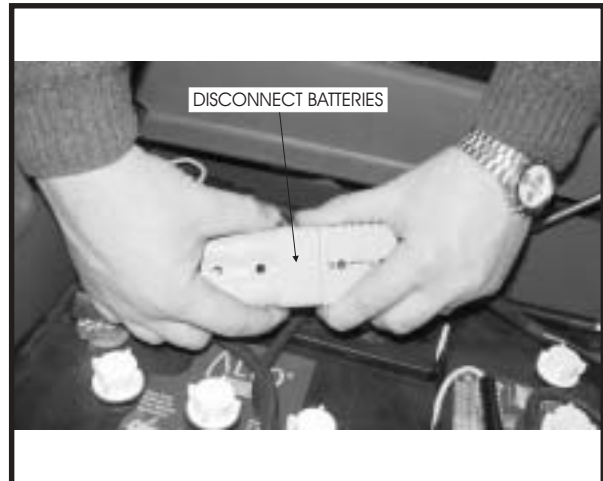

Fig. 53

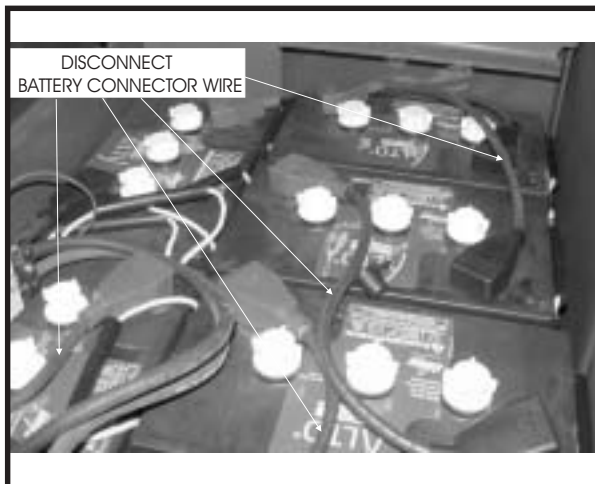

Fig. 54

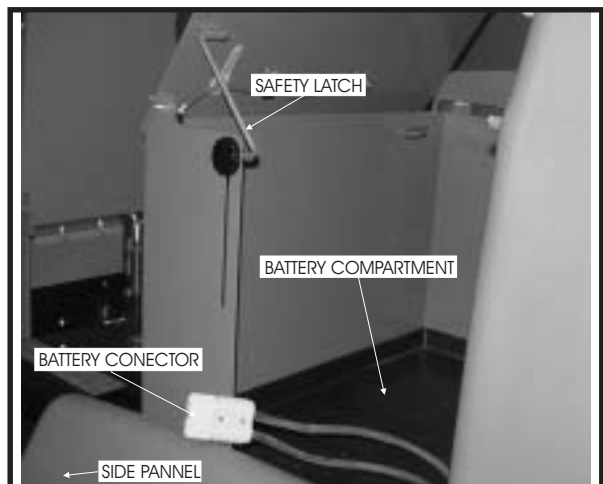

Fig. 55

### BATTERY REMOVAL

When removing batteries

1. Lift the seat cover making sure the safety latch is secure in the notch.
2. Remove the side panel to gain access to battery compartment.
3. Unplug the battery connector assembly from the battery to the machine connector assembly.
4. Disconnect the battery connector wires from the batteries.
5. Remove battery spacers holding batteries in place.
6. Use a 100 lb. (454 KG) lifting mechanism to lift and remove batteries.

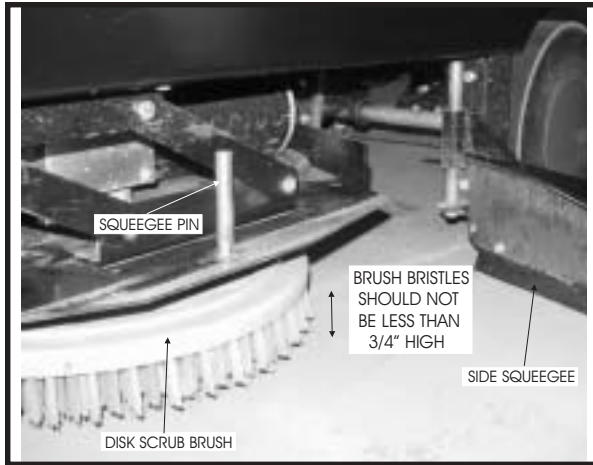

Fig. 56



Fig. 57

### REPLACING THE SCRUB BRUSHES

Replace Scrub Brushes when the bristles become worn to 3/4" as shown in figure 56 and 57.

1. Lower scrub brushes.
2. Swing open side squeegees
3. Lift scrub brushes
4. The scrub brush is held in place by a ring. Pull the brush straight down to remove it.
5. Push a new brush onto the scrub brush driver until it clicks in place.
6. Lower Scrub Deck to the NORMAL position and check the brush for proper floor contact.
7. Replace side squeegees.

### REPLACING PADS ON A PAD DRIVER

Install a new pad when the old pad is worn or dirty. The pad driver assembly is removed and installed the same way a standard scrub brush is. (See replacing the scrub brushes) To change pad follow this procedure.

1. The pad driver is held in place by a ring. Pull the pad driver straight down to remove it.
2. Remove the pad holder using the spring wire retainer.
3. Replace the worn pad.

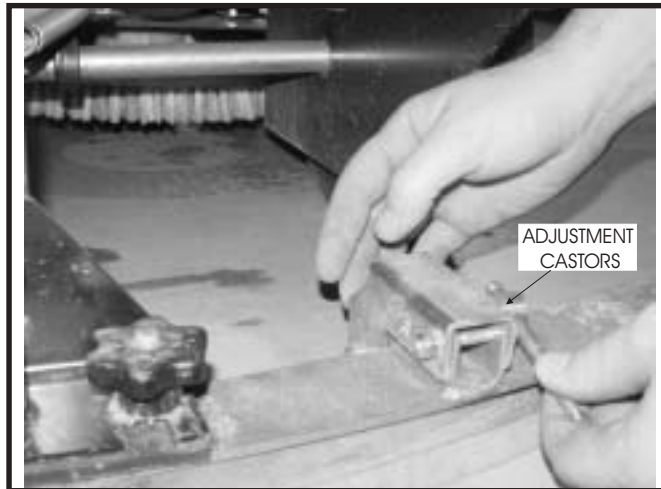

Fig. 58

**SQUEEGEE CASTER WHEEL ADJUSTMENT**

Adjust if squeegee leaves water on floor. The wheels must be 3/16" (.476 cm) above the floor.

1. Set the parking brake.
2. Turn the key switch to the on position.
3. Put the Squeegee Blade Switch in the lower position.
4. Turn the key switch to the on position. This will turn off the vacuum fans.
5. Loosen the wheel brackets by turning the adjustment handles.
6. Adjust the wheels to 3/16" (.476 cm) above the floor.
7. Tighten the wheel brackets with the adjustment handles.



Fig. 59

**MAINTENANCE FOR THE REAR SQUEEGEE**

To remove the squeegee, follow this procedure:

1. Remove the squeegee assembly by loosening the two knobs that attach the squeegee to the machine as shown in figure 59. Pull the squeegee assembly off.
2. Inspect the squeegee blade.
3. If the blade is worn, turn the blade so that a new edge is in the wiping position.
4. Reinstall squeegee assembly on the machine.



**Note**

**Toothed lock washers must be on top of support plate**

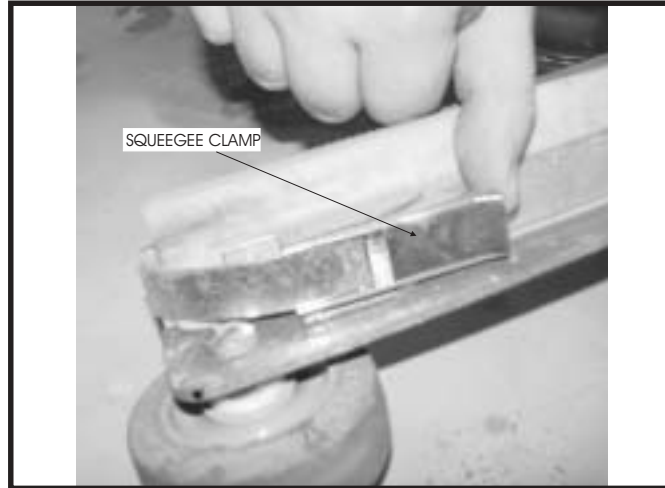

Fig. 60

### **SQUEEGEE BLADE REPLACEMENT**

Replace if front or rear blades are worn or damaged.

1. Set the parking brake.
2. Turn the key to the on position.
3. Put the Squeegee Blade Switch in the lower position.
4. Turn the key switch to the off position.
5. Remove the rear squeegee assembly.
6. Loosen the strap clamp.
7. Remove the old blades.

Push the new blades in until they are against the top of the squeegee. Retighten clamp

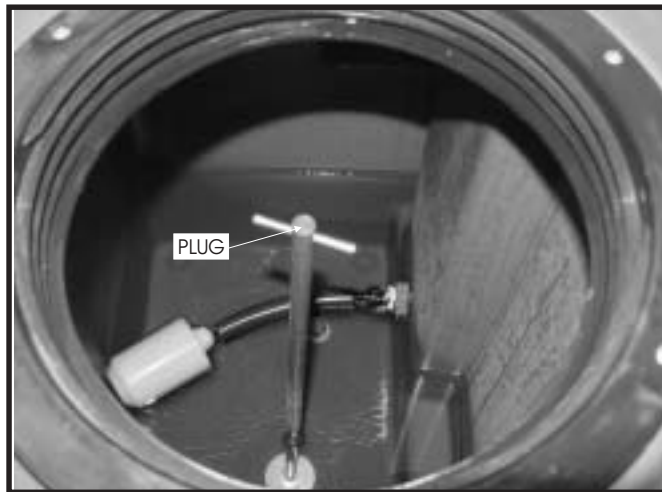

Fig. 61

### **TO DRAIN SOLUTION TANK**

Remove the cover from the solution tank, rotate the handle on the drain plug counterclockwise and then pull up as shown in figure 61. After the tank has drained, flush out with clean water and reinstall the plug.

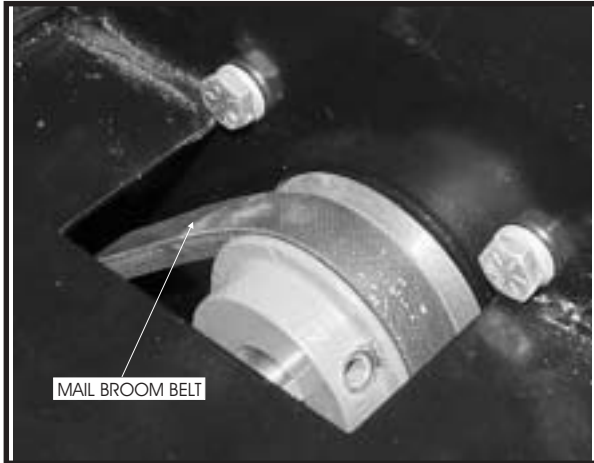

Fig. 62

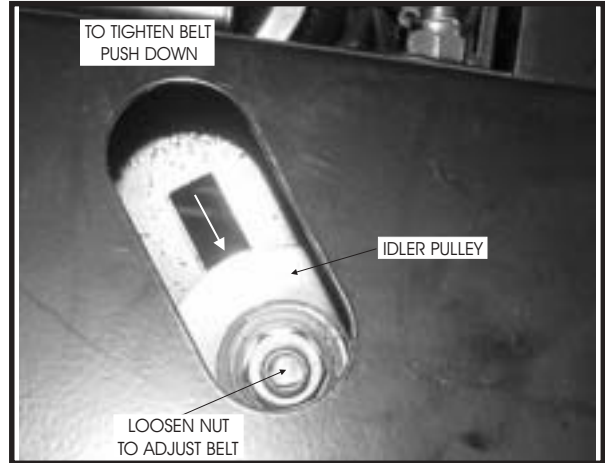

Fig. 63

**PRE SWEEP (OPTION)**

**Main Broom Belt**

1. Check belt tension adjustment as shown in figure 62.
2. Loosen idler pulley as shown in figure 63.
3. Move in slot in main frame.
4. Retighten.



Fig. 64

**Side Broom Belt**

1. Check belt tension adjustment as shown in figure 64.
2. Loosen pulley and broom nut.
3. Force pulley and broom forward.
4. Retighten.

## MAINTENANCE

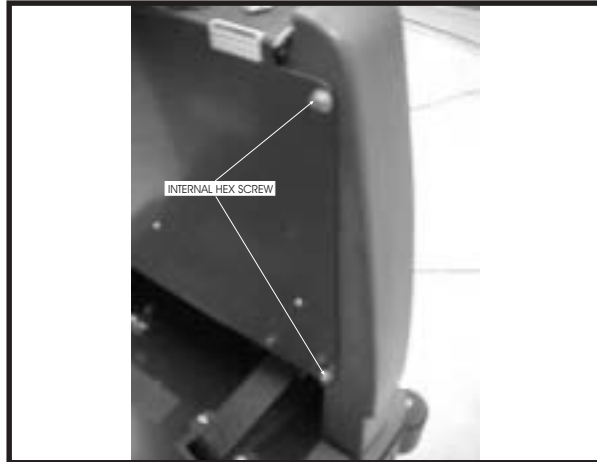

Fig. 65

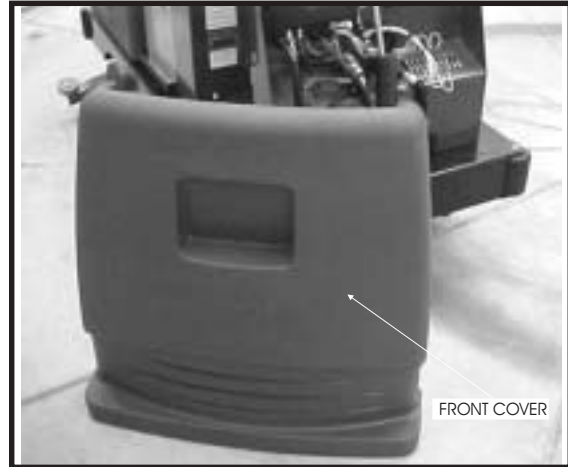

Fig. 66

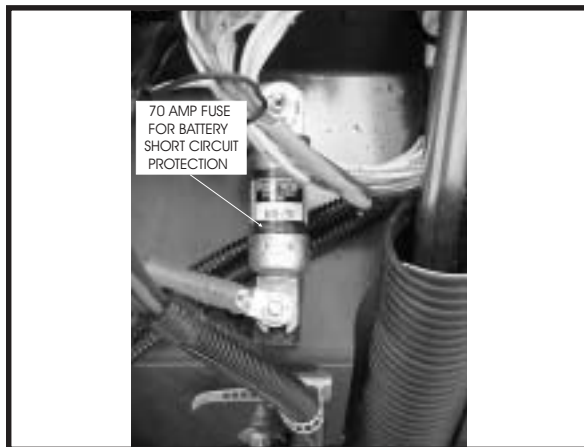

Fig. 67

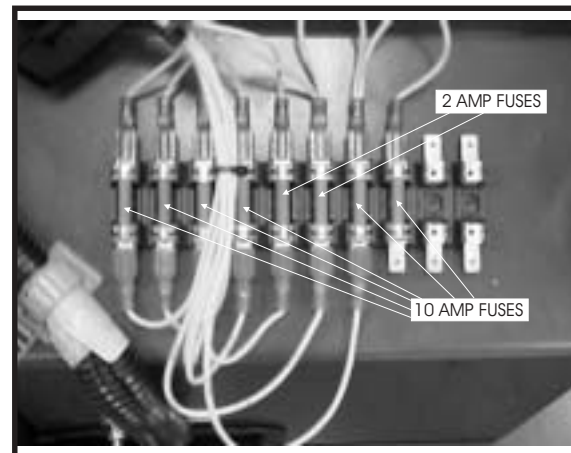

Fig. 68

### FUSE REPLACEMENT

To replace fuses unscrew the four internal hex screws, and then remove the front cover as shown in figure 65 and 66. Check fuses with an amp meter to locate the blown fuse. Replace the fuse with one of exactly the same size as shown in figure 67 and 68. Replace the cover and tighten the internal hex screws.

These fuses are manufactured by: Cooper-Bussmann, Inc., P.O. Box 14460, St. Louis, MO 63178-4460

#### Figure 67

##### Fuse Part No.

8-28-05019 (American-Lincoln)

ACK-70 (Cooper Bussmann)

#### Figure 68

##### Fuse Part Nos.

2-00-05861 (American-Lincoln/2 amp)

ABC-2 (Cooper Bussmann/2 amp)

2-00-05860 (American-Lincoln/10 amp)

ABC-10 (Cooper-Bussmann/10 amp)

**FUSES**



Fig. 69

- |        |                                     |
|--------|-------------------------------------|
| Fuse 1 | 10 Amp Scrub Deck Actuator Fuse     |
| Fuse 2 | 10 Amp Scrub Deck Actuator Fuse     |
| Fuse 3 | 10 Amp Squeegee Actuator Fuse       |
| Fuse 4 | 10 Amp Squeegee Actuator Fuse       |
| Fuse 5 | 2 Amp Water Flow Control Valve Fuse |
| Fuse 6 | 2 Amp Tank Float Switch Fuse        |
| Fuse 7 | 10 Amp Light and Horn Fuse          |
| Fuse 8 | 10 Amp Option Pump Fuse             |



**WARNING**

Replace fuses with the same size fuse to avoid damage to electrical components.

Power Panel fuses are manufactured by: Cooper-Bussmann, Inc., P.O. Box 14460, St. Louis, MO 63178-4460

**Fuse Part Nos.**

2-00-05861 (American-Lincoln/2 amp)  
 ABC-2 (Cooper Bussmann/2 amp)

2-00-05860 (American-Lincoln/10 amp)  
 ABC-10 (Cooper-Bussmann/10 amp)

## TROUBLESHOOTING

PROBLEM	PROBABLE CAUSE	REMEDY
Poor scrubbing.	<ol style="list-style-type: none"> <li>1. Worn scrub brushes.</li> <li>2. Incorrect method of operation.</li> <li>3. Wrong cleaning agent or mixture.</li> <li>4. Poor solution distribution.</li> <li>5. Brushes won't turn.</li> </ol>	<ol style="list-style-type: none"> <li>1. Replace brushes when scrub reaches worn zone. Brushes should be replaced when bristles worn to ¾".</li> <li>2. Check scrubbing procedure, brush pressure, type of cleaning agent and solution flow-all are important to the scrubbing process.</li> <li>3. Use American-Lincoln recommended cleaning materials.</li> <li>4. Check solution strainer and clean feed hoses for obstructions. Check valve control for proper operation.</li> <li>5. Check wiring connections.</li> </ol>
Water splashes from sides of scrub deck.	<ol style="list-style-type: none"> <li>1. Scrub deck bumpers, poor contact with floor.</li> <li>2. Squeegee blades worn or damaged.</li> <li>3. Too much solution.</li> </ol>	<ol style="list-style-type: none"> <li>1. Readjust blades for proper contact.</li> <li>2. Replace and adjust.</li> <li>3. Shut off solution flow 5' to 10' before making turns.</li> </ol>
Poor sweeping (Option).	<ol style="list-style-type: none"> <li>1. Broom jammed.</li> <li>2. Hopper full.</li> <li>3. Broom does not turn</li> <li>4. Hopper not installed correctly.</li> <li>5. Poor broom pattern.</li> <li>6. Flaps worn.</li> </ol>	<ol style="list-style-type: none"> <li>1. Remove obstruction.</li> <li>2. Empty.</li> <li>3. Adjust or replace broom belts. Reset circuit breakers adjust broom micro switches. Repair loose wire connections.</li> <li>4. Reinstall.</li> <li>5. Adjust sweep pattern.</li> <li>6. Repair or replace.</li> </ol>

Machine moves slow or erratically.	<ol style="list-style-type: none"><li>1. Battery charge low.</li><li>2. Brakes dragging.</li><li>3. Loose connection at foot pedal.</li><li>4. Overload of drive circuit.</li></ol>	<ol style="list-style-type: none"><li>1. Change.</li><li>2. Adjust.</li><li>3. Repair.</li><li>4. Remove obstruction, put drive pedal in neutral.</li><li>5. Adjust.</li></ol>
Machine does not move.	<ol style="list-style-type: none"><li>1. Blown fuse.</li><li>2. Battery unplugged.</li></ol>	<ol style="list-style-type: none"><li>1. Check fuse and replace if necessary.</li><li>2. Plug in battery.</li></ol>

## TROUBLE SHOOTING

<b>PROBLEM</b>	<b>PROBABLE CAUSE</b>	<b>REMEDY</b>
Machine moves slow or erratically	<ol style="list-style-type: none"> <li>1. Battery charge low</li> <li>2. Brakes dragging</li> <li>3. Loose connection at foot pedal</li> <li>4. Overload of drive circuit</li> </ol>	<ol style="list-style-type: none"> <li>1. Change</li> <li>2. Adjust</li> <li>3. Repair</li> <li>4. Remove obstruction, put drive pedal in neutral, adjust</li> </ol>
Machine does not move	<ol style="list-style-type: none"> <li>1. Blown fuse</li> <li>2. Battery unplugged</li> </ol>	<ol style="list-style-type: none"> <li>1. Check fuse and replace if necessary</li> <li>2. Plug in battery</li> </ol>
Poor water pick up at squeegee	<ol style="list-style-type: none"> <li>1. Recovery tank full</li> <li>2. Squeegee is worn or damaged</li> <li>3. Clogged suction hose or pick up tool</li> <li>4. Loose connections between suction hose and squeegee</li> <li>5. Vacuum motors not running</li> <li>6. Plugged filter</li> <li>7. Vacuum float cage clogged</li> <li>8. Vacuum float shut off</li> <li>9. Air leaks in suction hose and connection</li> <li>10. Air leaks at recovery tank cover and/or manifold hose</li> <li>11. Drain hose or drain plug leaking or not closed properly</li> </ol>	<ol style="list-style-type: none"> <li>1. Empty tank</li> <li>2. Examine squeegee rubber blade for cuts or worn spots/replace if necessary</li> <li>3. Disconnect suction hose from squeegee; flush squeegee and hose thoroughly</li> <li>4. Check all hose connections for looseness or damage</li> <li>5. Reset circuit breaker or repair loose connection</li> <li>6. Clean filter element in vacuum manifold</li> <li>7. Clean perforated metal thoroughly</li> <li>8. Excessive foam build up; change cleaning chemical mixture (use A-L approved material)</li> <li>9. Repair or replace hose and connections</li> <li>10. Repair or replace seal and hose</li> <li>11. Close, repair or replace drain plug in recovery tank</li> </ol>
Water spills from squeegee	<ol style="list-style-type: none"> <li>1. Side squeegee blades have poor contact with floor</li> <li>2. Squeegee blades worn or damaged</li> <li>3. Too much solution being applied before making turns</li> <li>4. Brushes rotating opposite direction</li> </ol>	<ol style="list-style-type: none"> <li>1. Readjust blades for proper contact</li> <li>2. Replace and adjust blades</li> <li>3. Shut off solution flow 5-10 feet prior to making turn</li> <li>4. Check position of switches</li> </ol>
Squeegee leaves wet spots	<ol style="list-style-type: none"> <li>1. Lift actuator out of adjustment</li> <li>2. Squeegee wheels out of adjustment</li> </ol>	<ol style="list-style-type: none"> <li>1. Adjust</li> <li>2. Adjust</li> </ol>
Squeegee makes excessive noise	<ol style="list-style-type: none"> <li>1. Blades worn or damaged</li> </ol>	<ol style="list-style-type: none"> <li>1. Replace</li> </ol>

---

REMOVE & INSERT 11 X 17  
**ELECTRICAL SCHEMATIC**  
**PG 53**

---

REMOVE & INSERT 11 X 17  
**WIRE HARNESS CONNECTIONS**  
**PG 54**



## WIRE HARNESS ROUTING & CONNECTIONS

---

<b>ITEM</b>	<b>QTY</b>	<b>PART NUMBER</b>	<b>DESCRIPTION</b>
1	1	0795-169	MACHINE HARNESS
2	1	0795-175	TRACTION MOTOR HARNESS
3	1	0795-176	BATTERY-POWER PANEL HARNESS

---

REMOVE & INSERT 11 X 17

**WIRE HARNESS ROUTING**  
**PG 57**

---

**11 x 17**  
**WIRE HARNESS CONNECTIONS-SPRAY WAND**  
**PG 58**

## TRIO SCRUBBER DIAGNOSTIC CODES

CODE	PGDT TECHNICAL DESCRIPTION	PROBABLE CAUSE	SERVICE ACTION
0003	EEPROM program checksum error 2	Memory corrupt.	Replace controller if not cleared by disconnecting batteries for 1 minute.
0100	Running checksum 1		
0204	EEPROM program checksum error 1		
0705	2.5V reference error	All 070x codes - Wiring short circuit between Tiller Hi & Lo Ref.	Check for wiring short circuits on the Trio's 20-way connector, the LCD's 16-way connector (if used) & the wiring to front panel switches & controls, and the actual switches & controls.
0706	High switch reference error		
0810	Tiller fault 1	All 081x codes - Throttle wiring short or open circuits.  0816 & 0817 can be caused by incorrect programming of the ISO test parameter.	Check wiring for short circuits or broken wires on Trio's 20-way connector, the LCD's 5-way connector (if used) & the wiring to front panel speed/throttle control, and the actual control.
0811	Tiller maximum wiper difference error		
0812	Tiller maximum pull-down difference error		
0813	Tiller maximum pull-safe difference error		
0814	Tiller reference error		
0815	Tiller lo reference error		
0816	Tiller hi reference ISO error		
0817	Tiller lo reference ISO error		
0818	Tiller error both have readings		
0A01	Power down error	Controller fault.	Replace controller if not cleared by disconnecting batteries for 1 minute.
0B0B	EEPROM Q Overflow		
1310	Excessive current trip		
1500	Brake fault 1	All 150x codes - Check brake & wiring for open or short circuit.	Check the Trio's traction motor connection, check wiring from this connector down to the traction motor, checking all connections along the way. Otherwise, possible fault in traction motor's electro brake or possible controller fault.
1501	Brake fault 2		
1507	Brake overcurrent error		
1600	High battery voltage	Voltage exceeds maximum.	Check for poor or corroded battery connections. Can also be caused by charger being connected.
1704	Relay monitor failure	Possible controller fault.	Replace controller if not cleared by disconnecting batteries for 1 minute.
1705	Relay fault 1		
1706	Relay fault 2		
1800	Watchdog error		
1802	Watchdog voltage reference error		
1B20	Both clamps measuring current		
1B21	Traction phase overflow error		
1D02	Front end spec change	Tiller settings updated in program	Cycle the power by using the key switch.
1E03	Inhibit activated	Inhibit inputs - exact usage dependent on programming.	Remove or correct the cause of inhibit. Otherwise, check all wiring, including Trio 20-way connector for short circuits & breaks. Can also be incorrect machine programming/operation.
1E04	Inhibit activated 2		
2102	Progress counter error	Possible controller fault.	Replace controller if not cleared by disconnecting batteries for 1 minute.
2103	Progress counter error 2		
2C00	Low battery error	Low voltage warning.	Recharge batteries immediately.
2C01	Low battery error 2		

## TRIO SCRUBBER DIAGNOSTIC CODES CON'T.

CODE	PGDT TECHNICAL DESCRIPTION	PROBABLE CAUSE	SERVICE ACTION
	Soft battery lockout occurred	Dependent on programming.	Recharge batteries immediately.
	No output drive	Possible controller fault.	Replace controller if not cleared by disconnecting batteries for 1 minute.
	Tiller displace error	Throttle in drive position during switch on.	Incorrect operation of machine. Otherwise, check throttle mechanism condition; all wiring on machine for short circuits or breaks (including Trio 20-way, LCD 16-way if used, front panel switches & controls); actual switches & controls.
	Bridge fault 1	All 310x codes - probable short circuit of output device or wiring-can sometimes cause permanent Controller fault.	Check the Traction, Brush & Vac motor connections on Trio; check wiring from these connections down to the motors, also checking wiring all along the way for proper connections and short circuits. Check for the same on Trio's 14-way connector, as well as the wiring else where on the rest of machine. Otherwise, replace controller.
	Traction bridge fault		
	Brush/Vac bridge fault		
	Soft waiting for bridge to charge		
	Traction bridge fault 2		
	Bridge fault 2		
	Minfield mismatch	Possible Controller fault.	Replace controller if not cleared by disconnecting batteries for 1 minute.
	No internal timers		
	Internal timer out of range		
	A to D readings not finished before next read		
	Unknown mux channel		
	ADC module not ready error		
	Test trip latch 1	Possible Controller fault.	Replace controller if not cleared by disconnecting batteries for 1 minute.
	Test trip latch 2		
	Test trip latch 3		
	Test trip latch 8		
	Test trip latch 9		
	Test trip latch 10		
	Test trip latch 11		
	Test trip latch 12		
	Test trip latch 13		
	Test trip latch 14		
	Startup with push activated	All 70x codes-Check wiring of brake & freewheel switch	Check wiring for short circuits on Trio's 20-way connector, the LCD's 16-way connector (if used) & wiring to freewheel switch & switch itself. Check traction motor connection on Trio & wiring from this connector down to electromagnetic brake on traction motor, checking connections all the way. Can be caused by excessive pushing or rolling down an incline or incorrect operation of machine
	Push activated in drive mode		
	LCD module communications timeout	Wiring fault on 6-way serial link between Trio & LCD.	Check wiring & connections on both Trio & LCD 6-way connectors.
	LCD module settings corrupt	LCD memory corrupt	Disconnect batteries & wait 1 minute before reapplying power.
	Soft brush motor disconnected error	Open circuit on brush motors or brush motor wiring	Check brush motor connection to Trio & wiring from this connector down to brush motor, checking connections all the way. Otherwise, possible brush motor fault.

## TRIO SCRUBBER DIAGNOSTIC CODES CON'T.

7601	Soft brush current foldback	Brush current overload ("thermal" trip).	Incorrect programming, incorrectly specified brush motor, brush motor developing fault, excessive resistance on brushes or brushes pushing down too hard on floor.
7602	Soft brush current foldback 2	Brush current overload ("magnetic" trip).	Incorrectly specified brush motor; brush motor developing fault.
7603	Soft brush current foldback 3	Possible short circuit on brush motors or wiring.	Check brush motor connection on Trio, check wiring from this connection all the way down to brush motor. Otherwise, possible brush motor fault.
7604	Brush inhibit active	Dependent on programming.	Incorrect software program-check program. Otherwise, possible controller fault.
7700	Soft vacuum motor disconnected error	Open circuit on vac motors or vac motor wiring.	Check vac motor connection at Trio; check this connection down to vac motor & all wiring in between. Otherwise, possible vac motor fault.
7701	Soft vacuum current foldback	Vacuum current overload ("thermal" trip).	Incorrect programming; incorrectly specified vac motor; vac motor developing fault; debris in vac motor or airways blocked by debris.
7702	Soft vacuum current foldback 2	Vacuum current overload ("magnetic" trip).	Incorrect programming; incorrectly specified vac motor; vac motor developing fault.
7703	Soft vacuum current foldback 3	Possible short circuit on vac motor or vac motor wiring	Check vac motor connection at Trio; check this connection down to vac motor & all wiring in between. Otherwise, possible vac motor fault.
7800	Motor fault 1	Open circuit on traction motor or traction motor wiring.	Check traction motor connection on Trio; check wiring from this connector down to traction motor & all connections in between. Otherwise, possible traction motor fault.
7801	Traction over current error	Possible short circuit on traction motor or wiring.	Check traction motor connection on Trio; check wiring from this connector down to traction motor & all connections in between. Otherwise, possible traction motor fault.
7802	Traction motor in foldback state	Traction motor current has exceeded limit for foldback time.	Excessive driving up incline or machine has been up against an obstacle or step.
7900	Emergency stop error	E-stop input active or wiring fault.	Check for wiring short circuits on Trio's 20-way connector, the LCD's 16-way connector (if used) & the wiring to emergency stop switch & switch itself. Otherwise, incorrect operation of machine.
7901	Belly button switch activated	E-stop input active or wiring fault (programmed as belly button).	Check for wiring short circuits on Trio's 20-way connector, the LCD's 16-way connector (if used) & the wiring to emergency stop switch & switch itself. Otherwise, incorrect operation of machine.